

Physics 8 — Wednesday, November 20, 2019

- ▶ HW11 is “due” on Friday, but you can turn it in on Monday, Nov 25, as it will probably take us an extra day to get through the material on beams.
- ▶ HW help: (Bill) Wed 4-6:30pm DRL 3C4, (Brooke/Grace) Thu 6-8pm DRL 2C4.
- ▶ This week, read/skim O/K Ch8 (more about beams).
- ▶ You may find my “equation sheet” to be a helpful summary of the key results from the Onouye/Kane reading:

<http://positron.hep.upenn.edu/p8/files/equations.pdf#page=12>

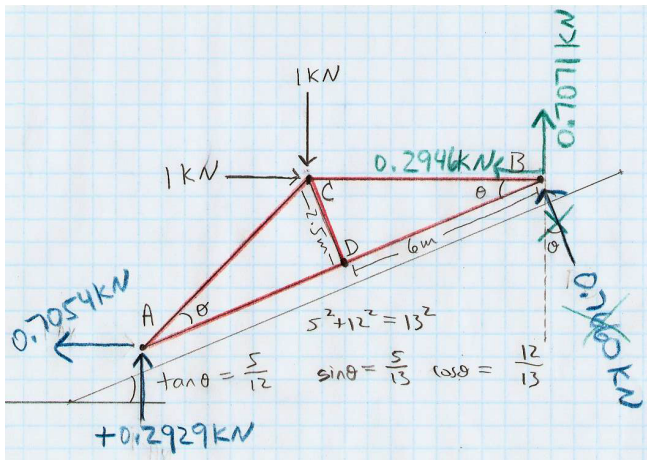

Here's what puzzled me about this statics problem last week: You can evaluate the moment (about A) due to the horizontal 1 kN force in two ways — with the same result, of course:

- ▶ how we did it: $-1 \text{ kN} \times 6.5 \text{ m} \sin(2\theta) = 4.615 \text{ kN} \cdot \text{m}$
- ▶ clever, trickier way: $-1 \text{ kN} \times 12 \text{ m} \sin \theta = 4.615 \text{ kN} \cdot \text{m}$

We discovered a geometrical proof that $\sin(2\theta) = 2 \cos \theta \sin \theta$.

Last time we worked out $V(x)$ and $M(x)$ for this cantilever beam.

Sign conventions: $V(x) > 0$ when beam left of x is pulling up on beam right of x . $M(x) > 0$ when beam is smiling.

Transverse shear $V(x)$ is the running sum of forces on beam, from $0 \dots x$, where upward = positive.

Bending moment $M(x)$ is the torque exerted by each side of the beam, cut at x , on the other side; but beware of sign convention.

$$V(x) = \frac{d}{dx} M(x)$$

The V diagram graphs the slope of the M diagram.

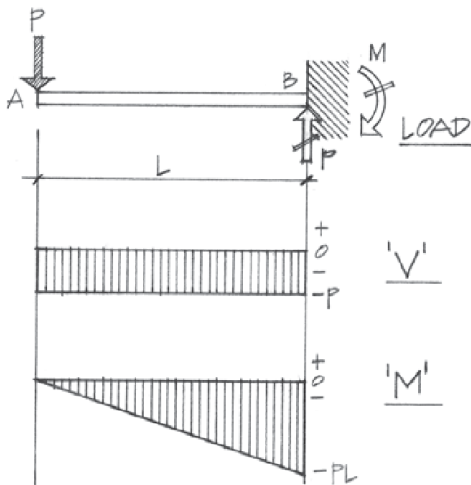

Draw V and M for this “simply supported” beam: $V(x)$ is running sum (up – down) of forces on beam. $M > 0$ when beam smiles.

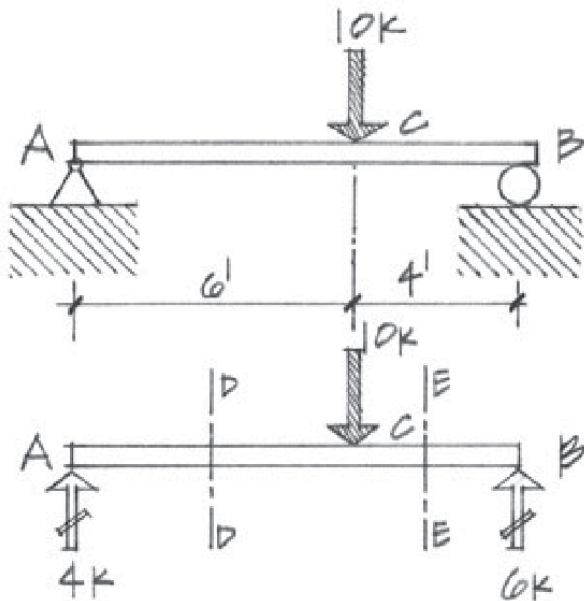

$$V(x) = \frac{d}{dx} M(x)$$

The shear (V) diagram equals the slope of the moment (M) diagram.

$$M(x) = \int V(x) dx$$

But be careful about the M values at the ends — depends how the beam is supported. A free, hinged, or roller-supported end has $M = 0$: support exerts no torque on that end. Fixed end of cantilever has $M \neq 0$.

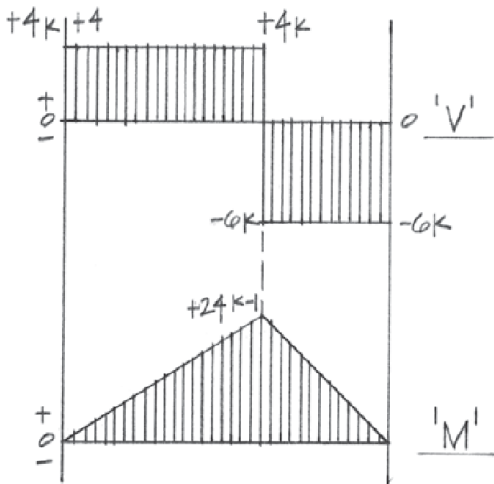
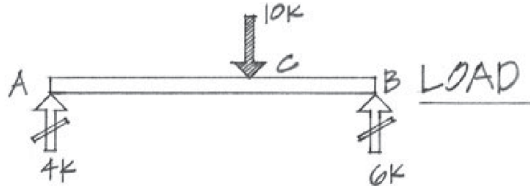

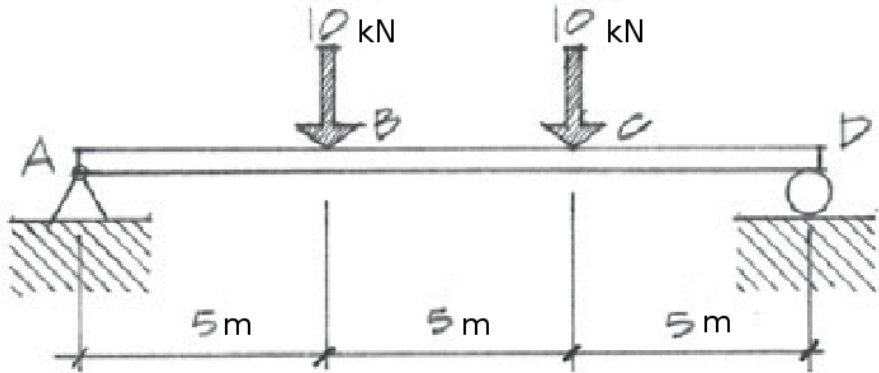

Let's try drawing load, V , and M diagrams for this simply-supported beam. Pretend the units are meters and kilonewtons rather than the original drawing's feet and kilopounds ("kips").

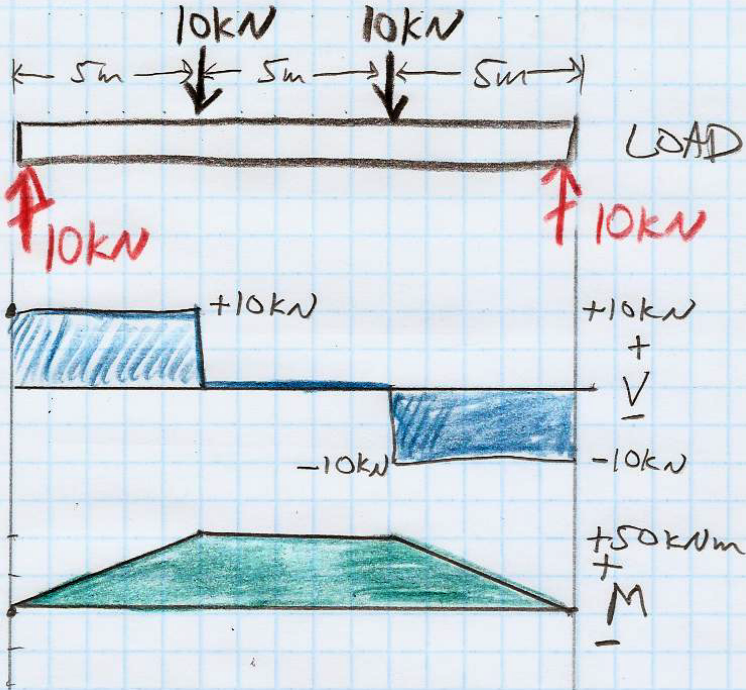

Shear (V) and moment (M) diagrams:

- ▶ First draw a “load diagram,” which is an EFBD that shows all of the vertical forces acting on the beam.
- ▶ The “shear diagram” $V(x)$ graphs the running sum of all vertical forces (both supports and loads) acting on the beam, from the left side up to x , where upward = positive, downward = negative.
- ▶ To draw the “moment diagram” $M(x)$, note that V is the slope of M :

$$V(x) = \frac{d}{dx} M(x)$$

- ▶ The change in M from x_1 to x_2 is given by

$$M_2 - M_1 = (x_2 - x_1) V_{1 \rightarrow 2}^{\text{average}}$$

- ▶ If an end of a beam is unsupported (“free”), is hinge/pin supported, or is roller supported, then $M = 0$ at that end. You can only have $M \neq 0$ at an end if the support at that end is capable of exerting a torque on the beam — for example, the fixed end of a cantilever has $M \neq 0$.

Let's try drawing $V(x)$ and $M(x)$ diagrams for a simply supported beam with uniform distributed load, as shown.

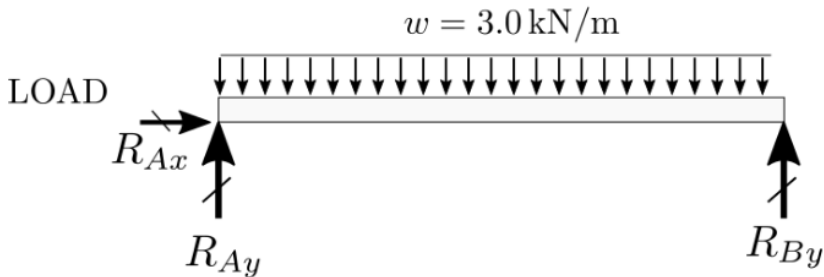
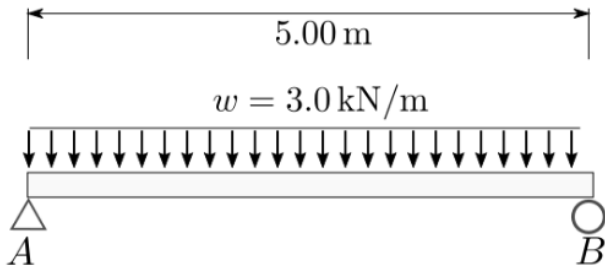

SHEAR

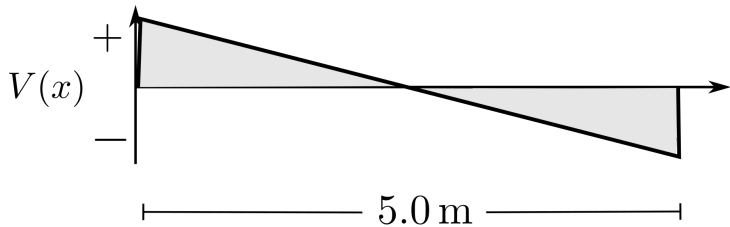

MOMENT

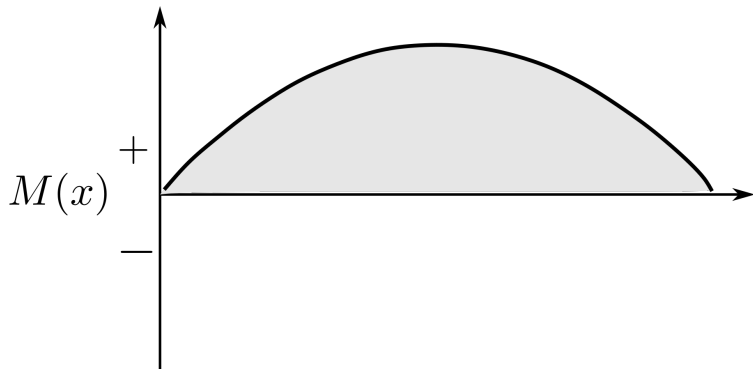

SHEAR

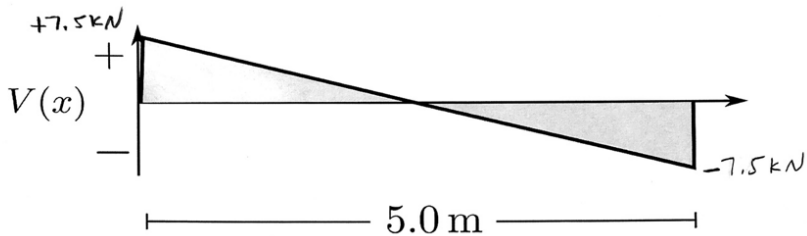

MOMENT

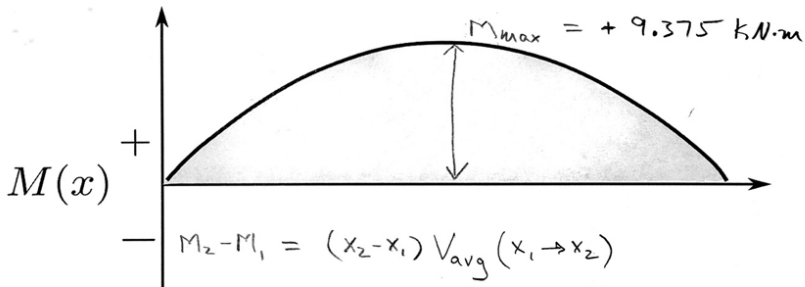

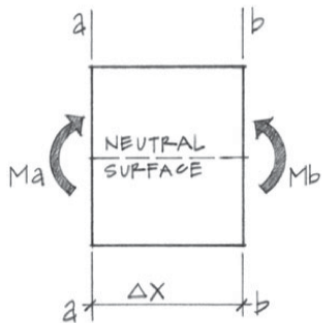

(a) Beam section between sections a and b .

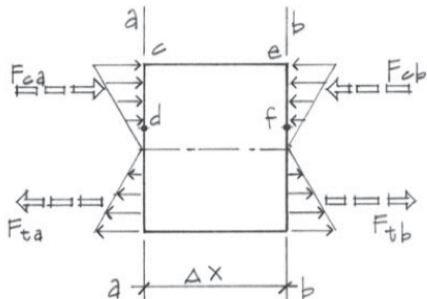

(b) Bending stresses on the beam section a - b .

Figure 8.19 Bending stress on a beam section.

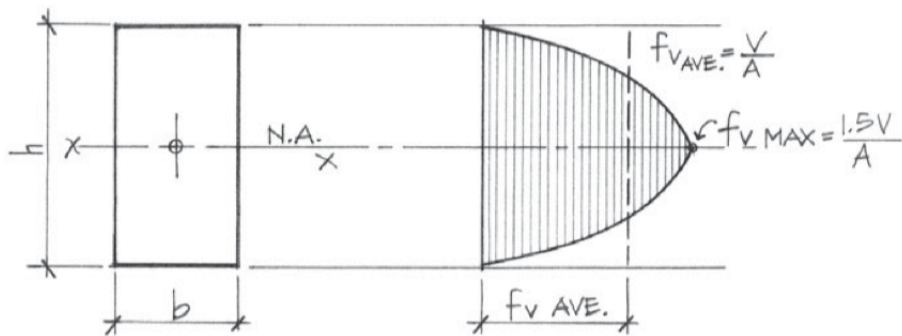

Cross Section.

Shear stress graph of a rectangular cross section.

Figure 8.26 Shear stress distribution—key points.

Questions for Prof. Farley!

- ▶ How do we explain the variation of shear stress across the cross-section of a beam — for example: where is shear stress largest for a simply supported beam with uniform distributed load, rectangular cross-section?
- ▶ Should we add to this course some physics of masonry structures, e.g. a classic Roman arch?
- ▶ For design criteria of a structure (O/K ch1), what is meant by redundancy and continuity?
- ▶ Z.E. question: how to study moments in complex shapes?
- ▶ Any others?!

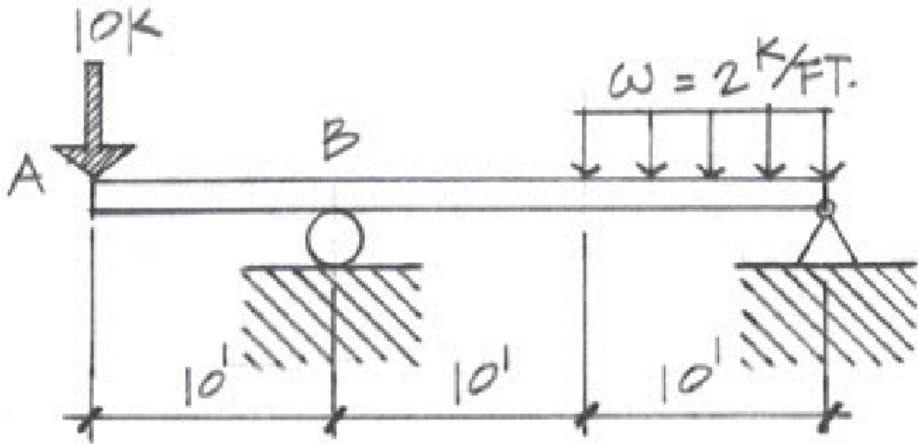

Draw shear (V) and moment (M) diagrams for this beam! Tricky!
 First one needs to solve for the support ("reaction") forces.

Note: in solving for the support forces, you replace distributed load w with equivalent point load. But when you draw the load diagram to find V and M , you need to keep w in its original form.

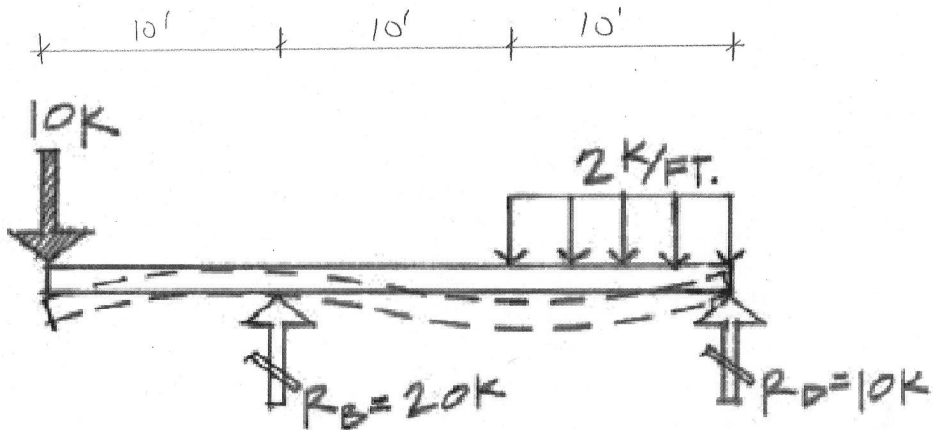

Remember that $V(x)$ is the running sum, from LHS to x , of vertical forces acting on the beam, with upward=positive.

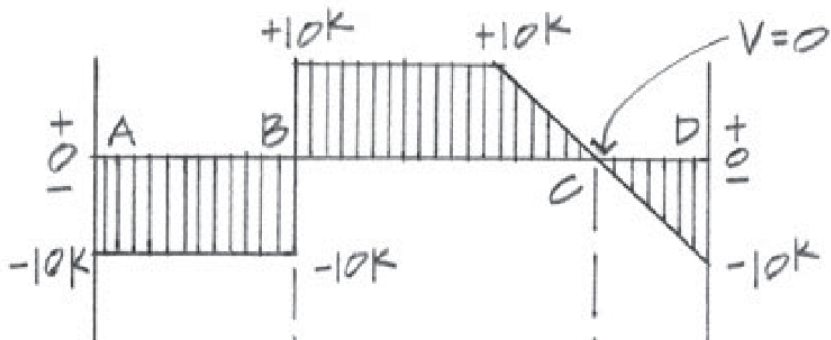
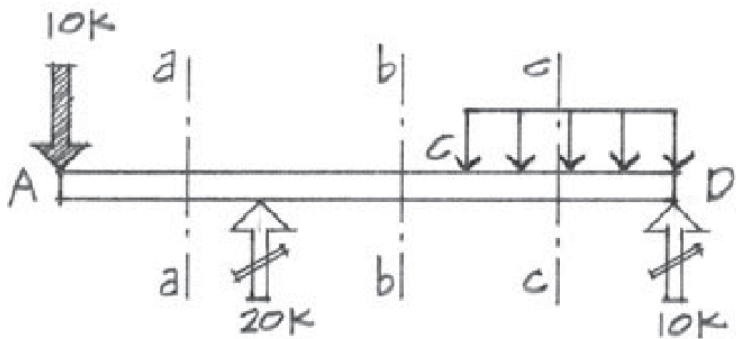

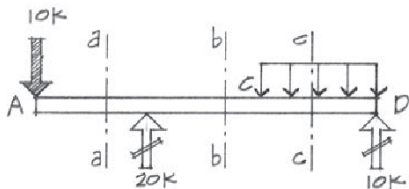

Load diagram.

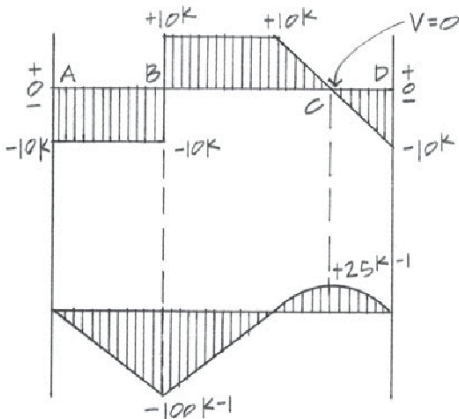

Shear diagram.

Moment diagram.

Neat trick: $M_2 - M_1 = (V_{\text{average}})_{1 \rightarrow 2} (x_2 - x_1)$

Draw load, V , and M diagrams for this simply supported beam with a partial uniform load.

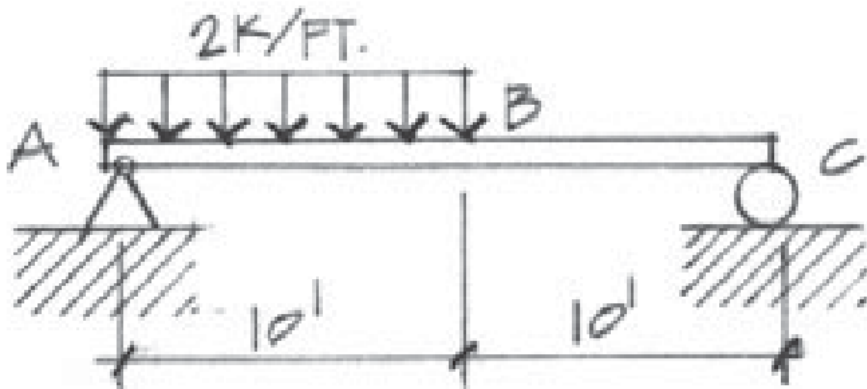

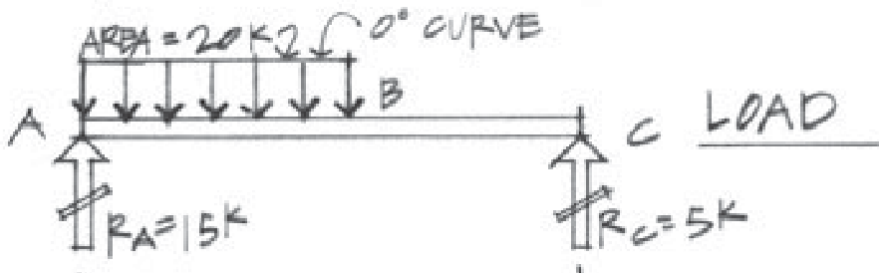
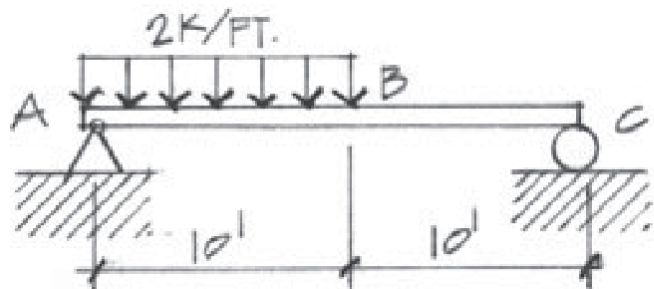

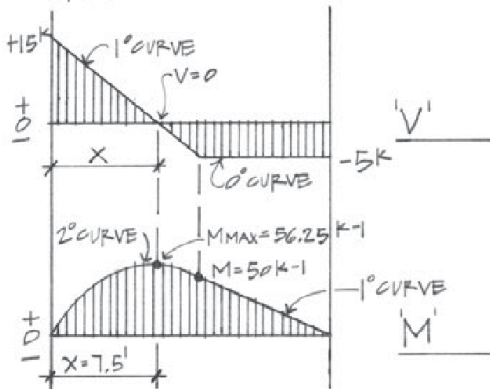
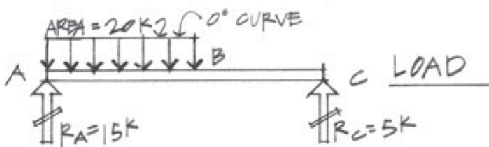
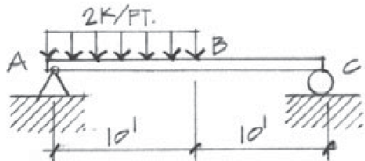

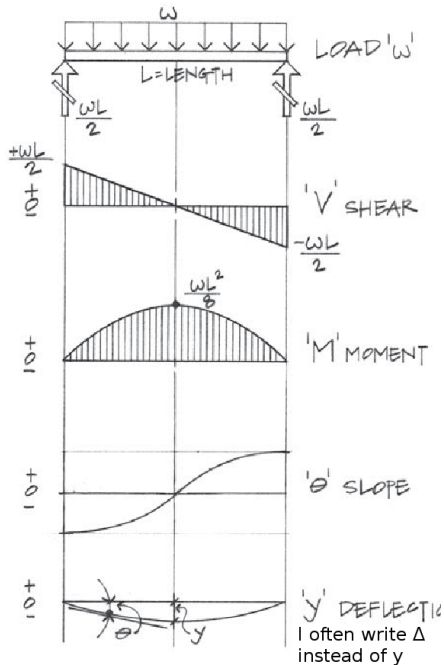
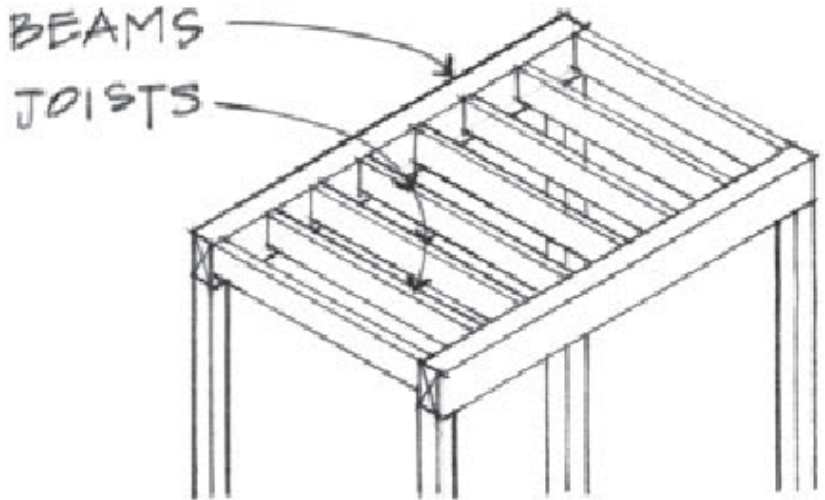

Figure 7.11 Relationship of load, shear, moment, slope, and deflection diagrams.

Why do we care about these beam diagrams, anyway? Usually the floor of a structure must carry a specified weight per unit area. The beams (beams, girders, joists, etc.) must be strong enough to support this load without failing and must be stiff enough to support this load without excessive deflection.



Beam criteria:

- ▶ Normal stress in the extreme fibers of the beam (farthest from neutral surface) must be smaller than the allowable bending stress, F_b , which depends on the material (wood, steel, etc.).
- ▶ This happens where $M(x)$ has largest magnitude.
- ▶ Shear stress (in both y (“transverse”) and x (“longitudinal”)) must be smaller than the allowable shear stress, F_v , which is also a property of the material (wood, steel, etc.).
- ▶ This happens where $V(x)$ has largest magnitude, and (surprisingly) is largest near the neutral surface.
- ▶ The above two are “strength” criteria. The third one is a “stiffness” criterion:
- ▶ The maximum deflection under load must satisfy the building code: typically $\Delta y_{\max} < L/360$.
- ▶ For a uniform load, this happens farthest away from the supports. If deflection is too large, plaster ceilings develop cracks, floors feel uncomfortably bouncy or sloped.
- ▶ The book also notes buckling as a beam failure mode.

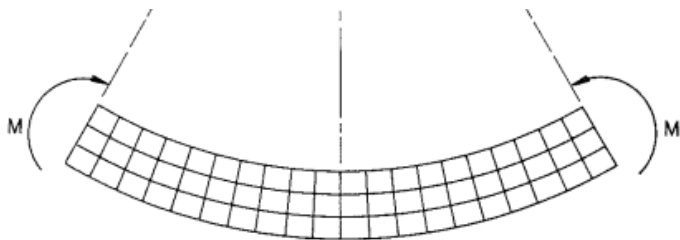

(b)

Fig. 6.5.

Navier's assumption. Originally plane and parallel sections (a) remain plane after bending (b), but converge onto a common center of curvature. This assumption can be illustrated with a rubber beam.

(In this illustration, bottom is in tension, top is in compression, as in a "simply supported" beam.)

A big topic from this week's reading was to see how an initially horizontal beam responds to the bending moment $M(x)$ by deforming into a curved shape.

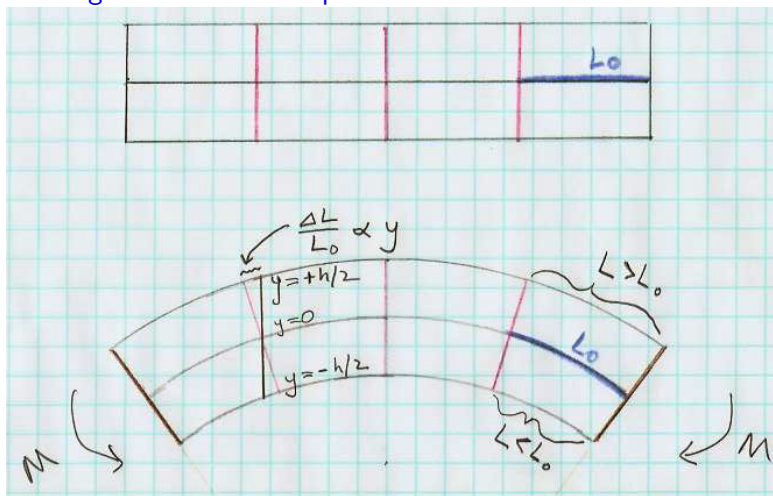

(In this illustration, top is in tension, as in a cantilever.)

Key idea: bending moment $M \propto \frac{1}{R}$, where R is the radius of curvature of the beam. For constant M , vertical lines converge toward common center of curvature.

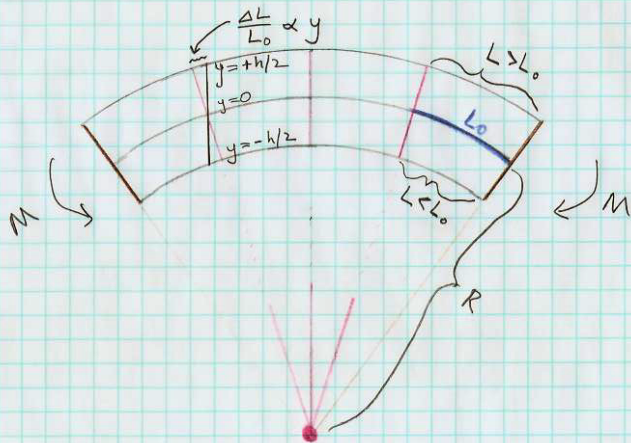
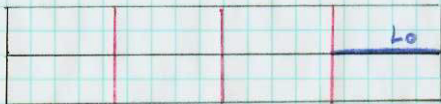

$$\text{strain} = \frac{\Delta L}{L_0} = \frac{y}{R}$$

where $y = 0$ is the neutral surface.

So in this case $y > 0$ is in tension and $y < 0$ is in compression.

If you think of wood fibers running along the beam's axis, then the fibers above the neutral surface ($y > 0$) are stretched in proportion to y , and the fibers below the neutral surface ($y < 0$) are compressed in proportion to $|y|$.

$$\text{strain} = \frac{\Delta L}{L} = \frac{y}{R}$$

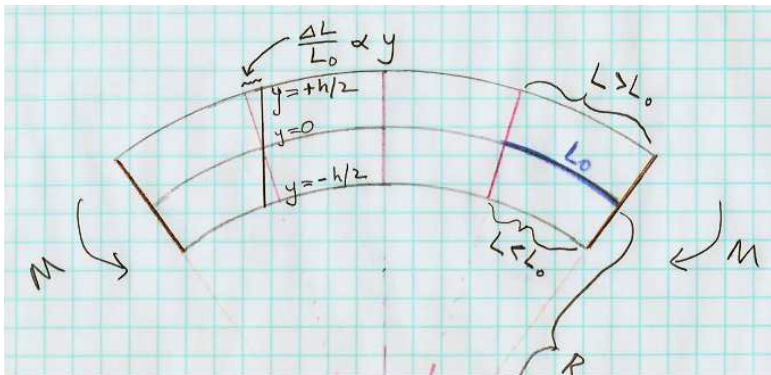

Now remember that $\frac{\Delta L}{L}$ is called (axial) *strain*, and force per unit area is called *stress*. For an elastic material, strain (e) \propto stress (f).

$$\frac{\Delta L}{L} = \frac{1}{E} \times \frac{\text{Force}}{\text{Area}} = \frac{1}{E} \times f \qquad e = \frac{1}{E} \times f$$

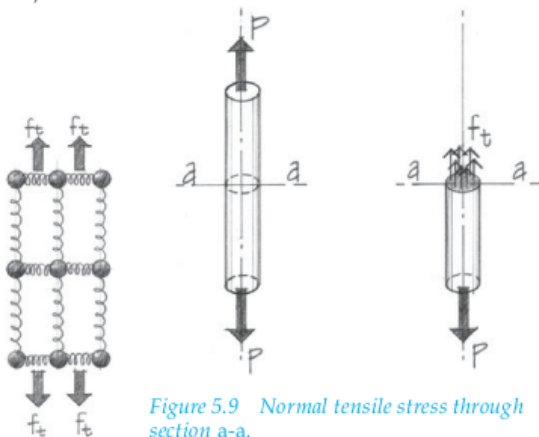
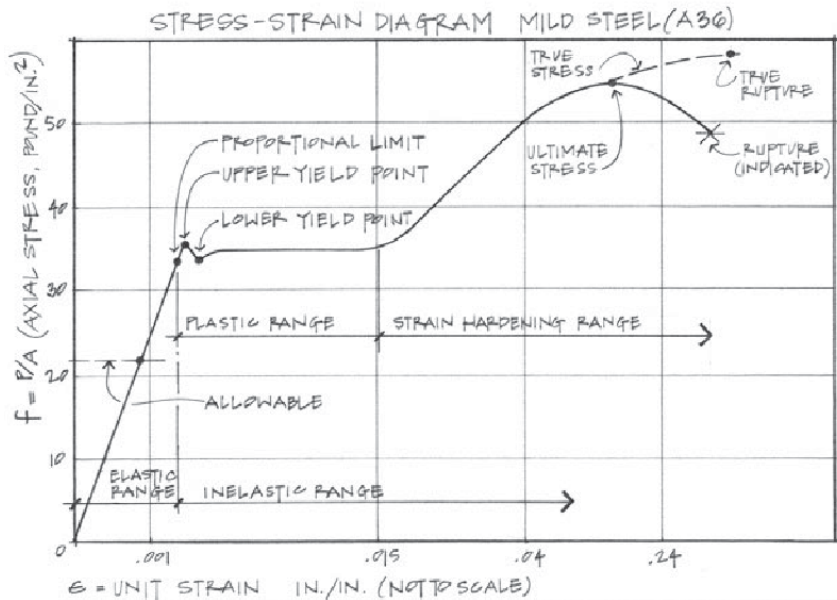

Figure 5.9 Normal tensile stress through section a-a.

In the elastic region, strain ($e = \Delta L/L$) is proportional to stress ($f = F/A$). $f = Ee$. The slope E is Young's modulus.



Plugging in $f = Ee$ to the bending-beam diagram:

$$\frac{y}{R} = \frac{\Delta L}{L} = e = \frac{f}{E}$$

we find the force-per-unit area (stress) exerted by the fibers is

$$f = \frac{Ey}{R}$$

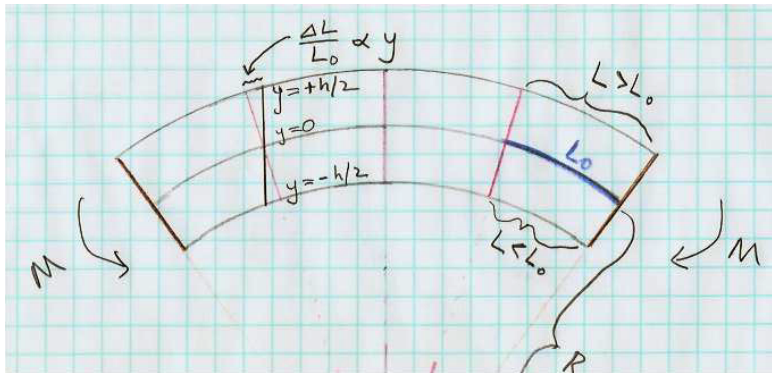

The force-per-unit area (stress) exerted by the fibers is

$$f = \frac{Ey}{R}$$

while the torque (bending moment dM , pivot about N.A.) exerted by each tiny fiber of area dA is proportional to its lever arm y

$$dM = y dF = y f dA = y \left(\frac{Ey}{R} \right) dA = \frac{E}{R} y^2 dA$$

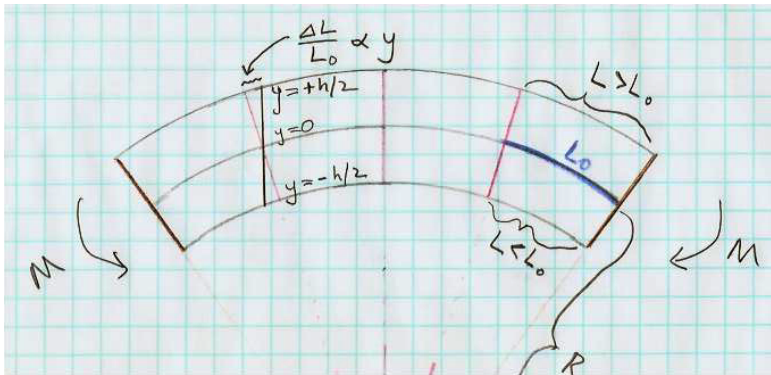

So the bending moment M exerted by a curved beam is

$$M = \frac{E}{R} \int y^2 dA = \frac{EI}{R}$$

where R is the curved beam's radius of curvature and $I = \int y^2 dA$ is the "second moment of area" a.k.a. "area moment of inertia."

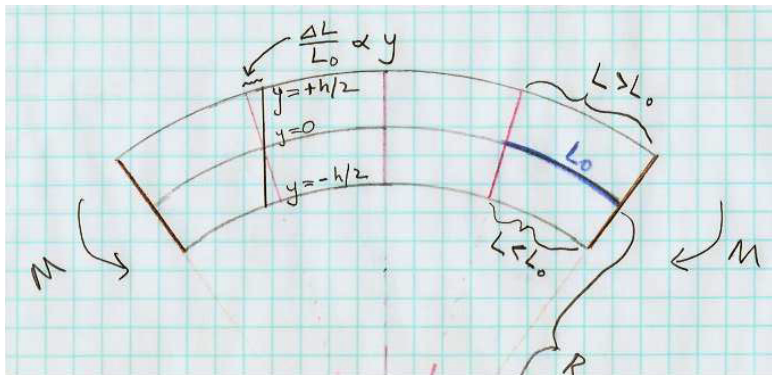

$$M = \frac{E}{R} \int y^2 dA = \frac{EI}{R}$$

Meanwhile, the vertical *deflection* Δ of a point along the beam is related to its curvature by (in limit where $\Delta \ll R$)

$$\frac{1}{R} \approx \frac{d^2\Delta}{dx^2}$$

so you can integrate the $M(x)$ curve twice to get deflection

$$\frac{d^2\Delta}{dx^2} = \frac{M}{EI} \Rightarrow \Delta(x) = \frac{1}{EI} \int dx \int M(x) dx$$

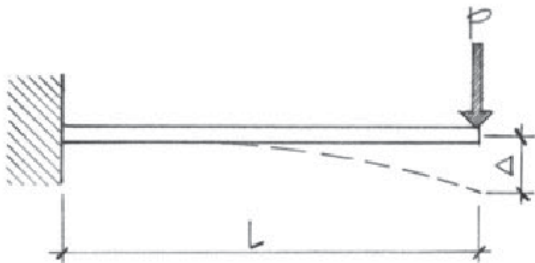

Calculus digression (not important — but you may be curious):

You may have seen in calculus that the “curvature” (which means $1/R$, where R is the radius of curvature) of a function $y = f(x)$ is

$$\frac{1}{R} = \frac{y''}{(1 + (y')^2)^{3/2}}$$

We are working in the limit $y' \ll 1$, so

$$\frac{1}{R} \approx y''$$

That's how we arrived at

$$\frac{1}{R} \approx \frac{d^2\Delta}{dx^2}$$

$$M = \frac{E}{R} \int y^2 dA = \frac{EI}{R}$$

Meanwhile, the vertical *deflection* Δ of a point along the beam is related to its curvature by (in limit where $\Delta \ll R$)

$$\frac{1}{R} \approx \frac{d^2\Delta}{dx^2}$$

so you can **integrate the $M(x)$ curve twice to get deflection**

$$\frac{d^2\Delta}{dx^2} = \frac{M}{EI} \Rightarrow \Delta(x) = \frac{1}{EI} \int dx \int M(x) dx$$

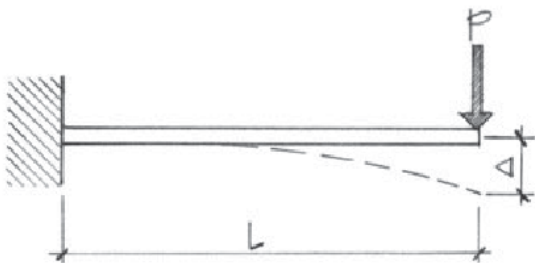

This Onouye/Kane figure writes “y” here for deflection, but I wrote “ Δ ” for deflection on the preceding pages (and they usually do, too), because we were already using y for “distance above the neutral surface.”

So you integrate $M(x)/EI$ twice w.r.t. x to get the deflection $\Delta(x)$.

The bending moment $M(x) = EI d^2\Delta/dx^2$, where E is Young's modulus and I is second moment of area.

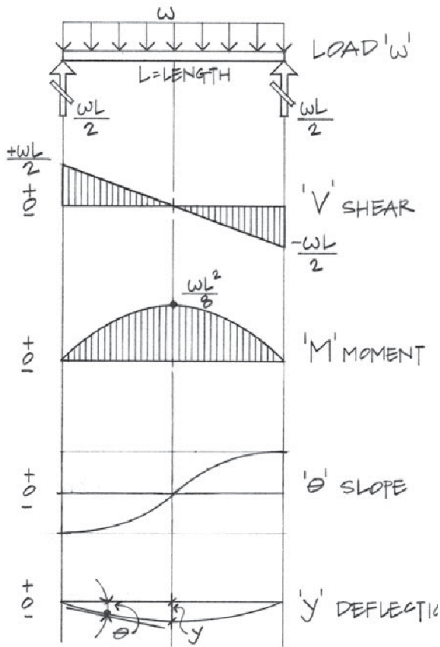
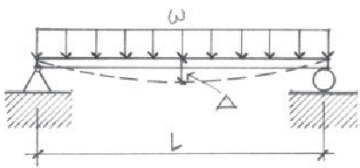
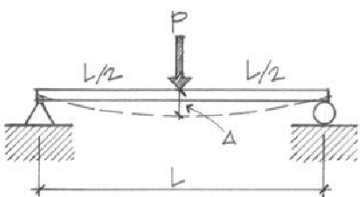
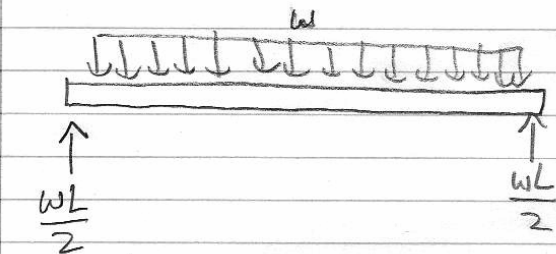

Figure 7.11 Relationship of load, shear, moment, slope, and deflection diagrams.

The most common deflection results can be found in tables.

Beam Load and Support	Actual Deflection*
 <p data-bbox="27 455 439 497">(a) Uniform load, simple span</p>	$\Delta_{\max} = \frac{5\omega L^4}{384EI}$ <p data-bbox="1097 341 1344 383">(at the centerline)</p>
 <p data-bbox="27 859 493 901">(b) Concentrated load at midspan</p>	$\Delta_{\max} = \frac{PL^3}{48EI}$ <p data-bbox="1097 704 1344 745">(at the centerline)</p>

FYI, here's where that crazy $(5wL^4)/(384EI)$ comes from!



$$\begin{aligned} V(x) &= \frac{wL}{2} - wx \\ &= w\left(\frac{L}{2} - x\right) \end{aligned}$$

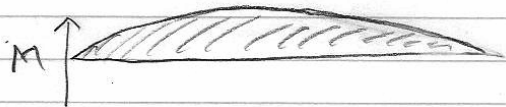

$$\begin{aligned} M(x) &= \frac{wLx}{2} - \frac{wx^2}{2} \\ &= \frac{w}{2} (Lx - x^2) \end{aligned}$$

(continued on next page)

Here's where that crazy $(5wL^4)/(384EI)$ comes from!

$$\begin{aligned}\Delta(x) &= -\frac{1}{EI} \int dx \int M(x) dx \\ &= -\frac{w}{2EI} \int dx \int (Lx - x^2) dx = -\frac{w}{2EI} \int dx \left(\frac{Lx^2}{2} - \frac{x^3}{3} + C_1 \right) \\ &= -\frac{w}{2EI} \left(\frac{Lx^3}{6} - \frac{x^4}{12} + C_1x + C_2 \right)\end{aligned}$$

$$\Delta(0) = 0 \Rightarrow C_2 = 0$$

$$\Delta(L) = 0 \Rightarrow \frac{L^4}{6} - \frac{L^4}{12} + C_1L = 0 \Rightarrow C_1 = -\frac{L^3}{12}$$

$$\Delta(x) = -\frac{w}{2EI} \left(\frac{Lx^3}{6} - \frac{x^4}{12} - \frac{L^3x}{12} \right)$$

$$\begin{aligned}\Delta_{\max} &= \Delta\left(\frac{L}{2}\right) = -\frac{w}{2EI} \left(\frac{L(L/2)^3}{6} - \frac{(L/2)^4}{12} - \frac{L^3(L/2)}{12} \right) \\ &= -\frac{wL^4}{2EI} \left(\frac{1}{48} - \frac{1}{192} - \frac{1}{24} \right) = -\frac{wL^4}{2EI} \left(-\frac{5}{192} \right) = \frac{5wL^4}{384EI}\end{aligned}$$

The 2 integration constants can be tricky. Simply supported:

$\Delta(0) = \Delta(L) = 0$. (For cantilever, $\Delta(0) = \Delta'(0) = 0$ instead.)

Maximum deflection is one of several beam-design criteria. You can see now how it relates to the load and $M(x)$ diagrams: Δ_{\max} comes from integrating $M(x)/(EI)$ twice w.r.t. x to get $\Delta(x)$.

For point load P at the end of a cantilever (for example), you get

$$\Delta_{\max} = \frac{PL^3}{3EI}$$

For uniform load w on simply-supported beam, you get

$$\Delta_{\max} = \frac{5wL^4}{384EI}$$

You just look these results up, or use a computer to calculate them.

Deflection is proportional to load, and inversely proportional to Young's modulus and to the second moment of area.

- ▶ More load \rightarrow more deflection
- ▶ Stiffer material \rightarrow less deflection
- ▶ Cross-section with larger $I = \int y^2 dA \rightarrow$ less deflection

Another beam-design criterion is maximum bending stress: the fibers farthest from the neutral surface experience the largest tension or compression, hence largest bending stress.

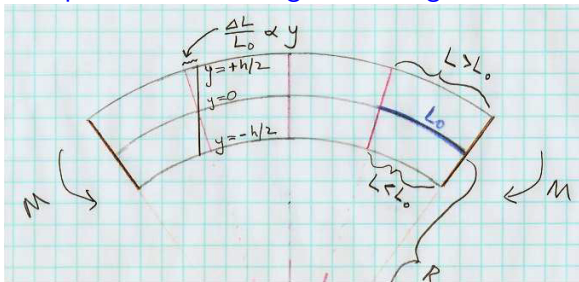

When we section the beam at x , bending moment $M(x)$ is

$$M = \frac{EI}{R}$$

which we can solve for the radius of curvature $R = EI/M$. Then the stress a distance y above the neutral surface is

$$f = Ee = E \frac{y}{R} = \frac{E y}{(EI/M)} = \frac{M y}{I}$$

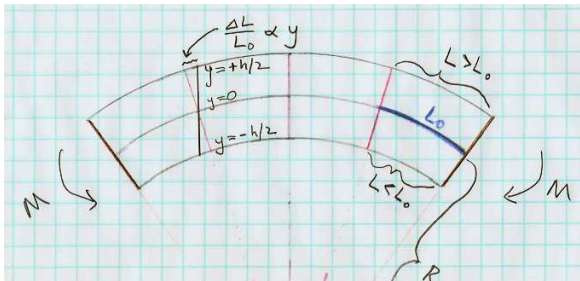

The bending stress a distance y above the neutral surface is

$$f = \frac{M y}{I}$$

The largest bending stress happens in the fibers farthest above or below the neutral surface. Call this largest distance $y_{\max} \equiv c$.

$$f_{\max} = \frac{M c}{I} = \frac{M}{(I/c)} = \frac{M}{S}$$

The ratio $S = I/c$ is called “section modulus.”

Bending stress in fibers farthest from neutral surface:

$$f_{\max} = \frac{M}{(I/c)} = \frac{M}{S}$$

So you sketch your load, V , and M diagrams, and you find M_{\max} , i.e. the largest magnitude of $M(x)$.

Then, the material you are using for beams (wood, steel, etc.) has a maximum allowable bending stress, F_b .

So then you look in your table of beam cross-sections and choose

$$S \geq S_{\text{required}} = \frac{M_{\max}}{F_b}$$

Beam criteria:

- ▶ Normal stress in the extreme fibers of the beam (farthest from neutral surface) must be smaller than the allowable bending stress, F_b , which depends on the material (wood, steel, etc.).
- ▶ This happens where $M(x)$ has largest magnitude.
- ▶ Shear stress (in both y (“transverse”) and x (“longitudinal”)) must be smaller than the allowable shear stress, F_v , which is also a property of the material (wood, steel, etc.).
- ▶ This happens where $V(x)$ has largest magnitude, and (surprisingly) is largest near the neutral surface.
- ▶ The above two are “strength” criteria. The third one is a “stiffness” criterion:
- ▶ The maximum deflection under load must satisfy the building code: typically $\Delta y_{\max} < L/360$.
- ▶ For a uniform load, this happens farthest away from the supports. If deflection is too large, plaster ceilings develop cracks, floors feel uncomfortably bouncy or sloped.
- ▶ The book also notes longitudinal buckling as a failure mode.

Maximum deflection is one of several beam-design criteria. Δ_{\max} comes from integrating $M(x)/(EI)$ twice w.r.t. x to get $\Delta(x)$.

For uniform load w on simply-supported beam, you get

$$\Delta_{\max} = \frac{5wL^4}{384EI}$$

You just look these results up, or use a computer to calculate them. But I had great fun calculating the $5/384$ myself!

Deflection is proportional to load, and inversely proportional to Young's modulus and to the second moment of area.

- ▶ More load \rightarrow more deflection
- ▶ Stiffer material \rightarrow less deflection
- ▶ Cross-section with larger $I = \int y^2 dA \rightarrow$ less deflection

Notice that putting a column in the middle of a long, uniformly loaded beam reduces Δ_{\max} by a factor of $2^4 = 16$. Alternatively, if you want to span a large, open space without intermediate columns or bearing walls, you need beams with large I .

Bending beam into circular arc of radius R gives strain e vs. distance y above the neutral surface.

$$e = \frac{\Delta L}{L_0} = \frac{y}{R}$$

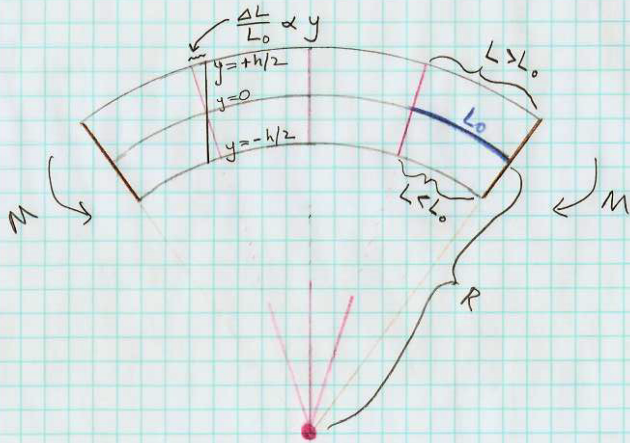

Hooke's Law $f = Ee$

gives stress $f = \frac{Ey}{R}$

Torque exerted by fibers of beam is

$$M = \int y (f \, dA) =$$

$$y \frac{Ey}{R} \, dA = \frac{E}{R} y^2 \, dA$$

$$M = \frac{EI}{R}$$

Eliminate $R \Rightarrow$

$$f = \frac{My}{I} = \frac{M}{I/y}$$

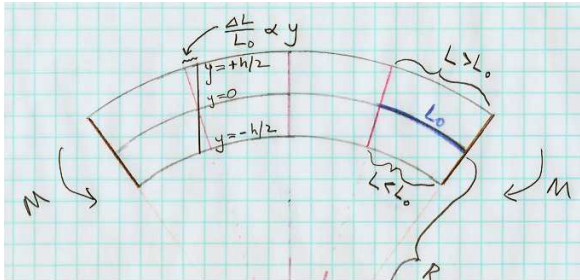

The bending stress a distance y above the neutral surface is

$$f = \frac{M y}{I}$$

The largest bending stress happens in the fibers farthest above or below the neutral surface. Call this largest distance $y_{\max} \equiv c$.

$$f_{\max} = \frac{M_{\max} c}{I} = \frac{M_{\max}}{(I/c)} = \frac{M_{\max}}{S}$$

The ratio $S = I/c$ is called “section modulus.” The load diagram gives you M_{\max} . Each material (wood, steel, etc.) has allowed bending stress f_{\max} . Then S_{\min} tells you how big a beam you need.

Example (using metric units!): A cantilever beam has a span of 3.0 m with a single concentrated load of 100 kg at its unsupported end. If the beam is made of timber having allowable bending stress $F_b = 1.1 \times 10^7 \text{ N/m}^2$ (was 1600 psi in US units), what minimum section modulus is required?

What is the smallest “2×” dimensional lumber (width = 1.5 inch = 0.038 m) whose cross-section satisfies this strength criterion?

Would this beam also satisfy a $\Delta_{\max} < L/240$ (maximum deflection) stiffness criterion? If not, what standard “2×” cross-section is needed instead?

$\Delta_{\max} = PL^3/(3EI)$ for a cantilever with concentrated load at end. Use Young's modulus $E = 1.1 \times 10^{10} \text{ N/m}^2$ for southern pine.

Cantilever of length L with point load P at free end.

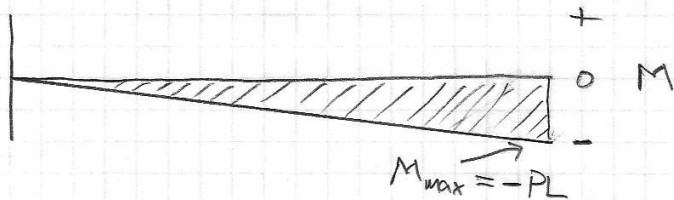
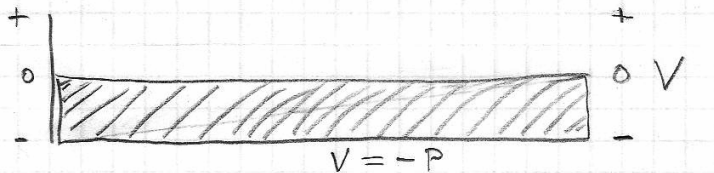
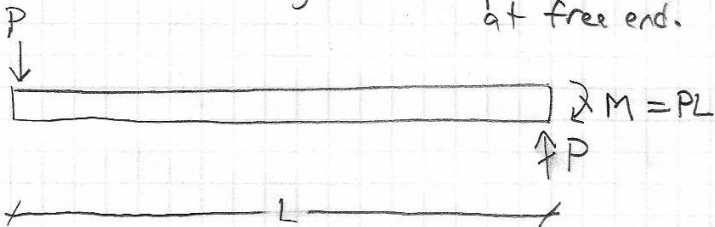

$$S_{\min} = \frac{|M_{\max}|}{f_{\text{allowed}}} = \frac{PL}{F_b} = \frac{(980 \text{ N})(3 \text{ m})}{1.1 \times 10^7 \text{ N/m}^2} = 26.7 \times 10^{-5} \text{ m}^3$$

$$\Delta_{\text{allowed}} = \frac{L}{240} = \frac{3.0 \text{ m}}{240} = 0.0125 \text{ m}$$

$$\Delta_{\max} = \frac{PL^3}{3EI} \Rightarrow I_{\min} = \frac{PL^3}{3E\Delta_{\text{allowed}}} = 64.2 \times 10^{-6} \text{ m}^4$$

I worked out b , h , I , and $S = I/c$ values in metric units for standard “2×” dimensional lumber.

	b	b	h	h	$I = bh^3/12$	$S = bh^2/6$
2 × 4	1.5 in	.038 m	3.5 in	.089 m	$2.23 \times 10^{-6} \text{ m}^4$	$5.02 \times 10^{-5} \text{ m}^3$
2 × 6	1.5 in	.038 m	5.5 in	.140 m	$8.66 \times 10^{-6} \text{ m}^4$	$12.4 \times 10^{-5} \text{ m}^3$
2 × 8	1.5 in	.038 m	7.5 in	.191 m	$21.9 \times 10^{-6} \text{ m}^4$	$23.0 \times 10^{-5} \text{ m}^3$
2 × 10	1.5 in	.038 m	9.5 in	.241 m	$44.6 \times 10^{-6} \text{ m}^4$	$37.0 \times 10^{-5} \text{ m}^3$
2 × 12	1.5 in	.038 m	11.5 in	.292 m	$79.1 \times 10^{-6} \text{ m}^4$	$54.2 \times 10^{-5} \text{ m}^3$

The numbers are nicer if you use centimeters instead of meters, but then you have the added hassle of remembering to convert back to meters in calculations.

	b	b	h	h	$I = bh^3/12$	$S = bh^2/6$
2 × 4	1.5 in	3.8 cm	3.5 in	8.9 cm	223 cm^4	50.2 cm^3
2 × 6	1.5 in	3.8 cm	5.5 in	14.0 cm	866 cm^4	124 cm^3
2 × 8	1.5 in	3.8 cm	7.5 in	19.1 cm	2195 cm^4	230 cm^3
2 × 10	1.5 in	3.8 cm	9.5 in	24.1 cm	4461 cm^4	370 cm^3
2 × 12	1.5 in	3.8 cm	11.5 in	29.2 cm	7913 cm^4	542 cm^3

Minor variation on same problem: A cantilever beam has a span of 3.0 m with a uniform distributed load of 33.3 kg/m along its entire length. If we use timber with allowable bending stress $F_b = 1.1 \times 10^7 \text{ N/m}^2$, what minimum section modulus is required?

What is the smallest “2×” dimensional lumber (width = 1.5 inch = 0.038 m) whose cross-section satisfies this strength criterion?

Would this beam also satisfy a $\Delta_{\max} < L/240$ (maximum deflection) stiffness criterion? If not, what standard “2×” cross-section is needed instead?

$\Delta_{\max} = wL^4/(8EI)$ for a cantilever with uniform load. Use Young's modulus $E = 1.1 \times 10^{10} \text{ N/m}^2$ for southern pine.

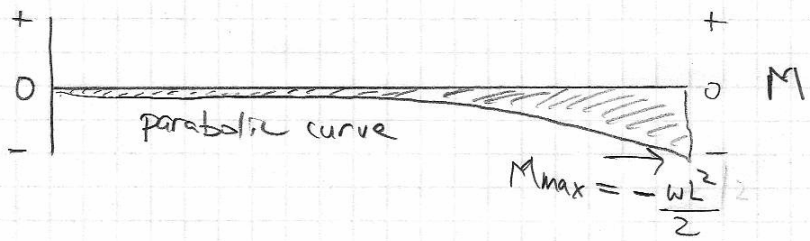
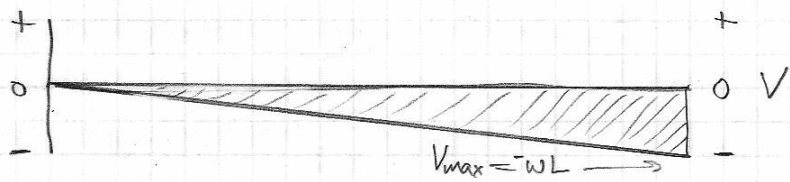
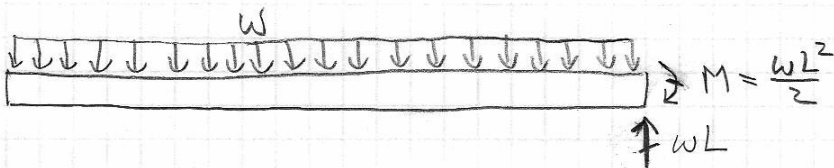

$$S_{\min} = \frac{|M_{\max}|}{f_{\text{allowed}}} = \frac{wL^2/2}{F_b} = \frac{(326 \text{ N/m})(3 \text{ m})^2/2}{1.1 \times 10^7 \text{ N/m}^2} = 13.3 \times 10^{-5} \text{ m}^3$$

$$\Delta_{\text{allowed}} = \frac{L}{240} = \frac{3.0 \text{ m}}{240} = 0.0125 \text{ m}$$

$$\Delta_{\max} = \frac{wL^4}{8EI} \Rightarrow I_{\min} = \frac{wL^4}{8E\Delta_{\text{allowed}}} = 24.0 \times 10^{-6} \text{ m}^4$$

2) Size a wood joist for a row house floor which spans 12 feet. Joists are spaced at 16 inches on center.

$f = 1,300$ psi
 $f = 85$ psi
 $E = 1.7 \times 10^6$ psi
 $LL = 60$ psf
 $DL = 30$ psf

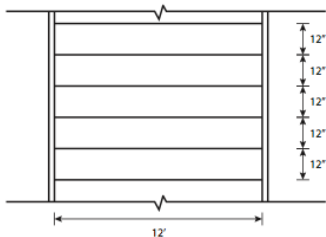

Plan View

Hint: remember that a "2 x 4" wood joist is only nominal; its true dimensions are "1.5 x 3.5" inches. (4 = 1.5, 6 = 5.5, 8 = 7.25, 10 = 9.25 inches)

(Here's a homework problem from ARCH 435.)

Actually, Home Depot's 2 x 10 really is 9.5 inches deep, not 9.25 inches, and 2 x 12 really is 11.5 inches deep.

A timber floor system uses joists made of “2 × 10” dimensional lumber. Each joist spans a length of 4.27 m (simply supported). The floor carries a load of 2400 N/m². At what spacing should the joists be placed, in order not to exceed allowable bending stress $F_b = 10000 \text{ kN/m}^2$ ($1.0 \times 10^7 \text{ N/m}^2$)?

(We should get an answer around 24 inches = 0.61 meters.)

8.6 A timber floor system utilizing 2×10 S4S joists spans a length of 14' (simply supported). The floor carries a load of 50 psf (DL + LL). At what spacing should the joists be placed? Assume Douglas Fir-Larch No. 2 ($F_b = 1,450$ psi).

Solution:

Based on the allowable stress criteria:

$$f = \frac{Mc}{I} = \frac{M}{S}$$

$$M_{\max} = S \times f_b = (21.4 \text{ in.}^3)(1.45 \text{ k/in.}^2) = 31 \text{ k-in.}$$

$$M = \frac{31 \text{ k-in.}}{12 \text{ in./ft.}} = 2.58 \text{ k-ft.}$$

Based on the bending moment diagram:

$$M_{\max} = \frac{\omega L^2}{8}$$

Therefore,

$$\omega = \frac{8M}{L^2}$$

Substituting for M obtained previously,

$$\omega = \frac{8(2.58 \text{ k-ft.})}{(14')^2} = 0.105 \text{ k/ft.} = 105 \text{ \#/ft.}$$

But

$$\omega = \#/\text{ft.}^2 \times \text{tributary width (joist spacing } s)$$

$$s = \frac{\omega}{50 \text{ psf}} = \frac{105 \text{ \#/ft.}}{50 \text{ \#/ft.}^2} = 2.1'$$

$$s = 25'' \text{ spacing}$$

Use 24'' o.c. spacing.

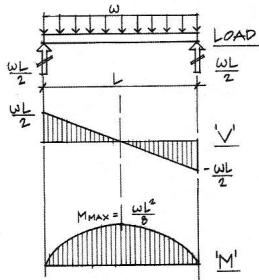
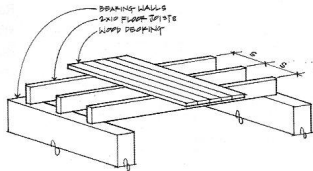

8.6 A timber floor system utilizing 2×10 S4S joists spans a length of 14' (simply supported). The floor carries a load of 50 psf (DL + LL). At what spacing should the joists be placed? Assume Douglas Fir-Larch No. 2 ($F_b = 1,450$ psi).

Solution:

Based on the allowable stress criteria:

$$f = \frac{Mc}{I} = \frac{M}{S}$$

$$M_{\max} = S \times f_b = (21.4 \text{ in.}^3)(1.45 \text{ k/in.}^3) = 31 \text{ k-in.}$$

$$M = \frac{31 \text{ k-in.}}{12 \text{ in./ft.}} = 2.58 \text{ k-ft.}$$

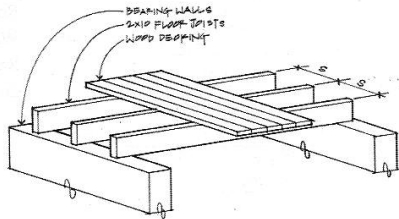

Based on the bending moment diagram:

$$M_{\max} = \frac{\omega L^2}{8}$$

Therefore,

$$\omega = \frac{8M}{L^2}$$

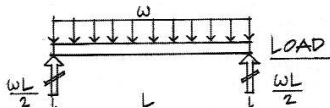

Based on the bending moment diagram:

$$M_{\max} = \frac{\omega L^2}{8}$$

Therefore,

$$\omega = \frac{8M}{L^2}$$

Substituting for M obtained previously,

$$\omega = \frac{8(2.58 \text{ k-ft.})}{(14')^2} = 0.105 \text{ k/ft.} = 105 \text{ \#/ft.}$$

But

$$\omega = \text{\#/ft.}^2 \times \text{tributary width (joist spacing s)}$$

$$s = \frac{\omega}{50 \text{ psf}} = \frac{105 \text{ \#/ft.}}{50 \text{ \#/ft.}^2} = 2.1'$$

$$s = 25'' \text{ spacing}$$

Use 24" o.c. spacing.

Note: Spacing is more practical for plywood subflooring, based on a 4 ft. module of the sheet.

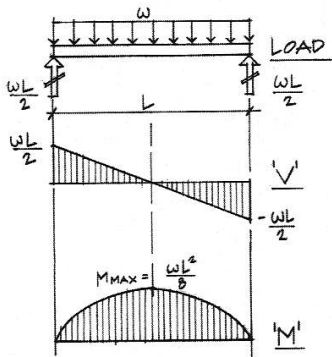

Using the method of sections, solve for the forces in members AB , BH , and HG in the truss shown below. Indicate whether each of these members is in tension or in compression. Use only one section cut through the truss.

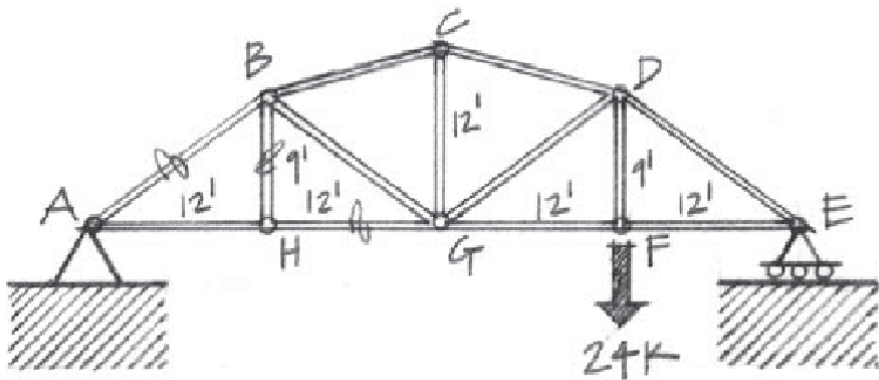

If we have time left, let's solve this truss problem together. It's actually pretty quick, using method of sections. First solve for vertical support force at A, then analyze left side of section.

Using the method of sections, solve for the forces in members AB , BH , and HG in the truss shown below. Indicate whether each of these members is in tension or in compression. Use only one section cut through the truss.

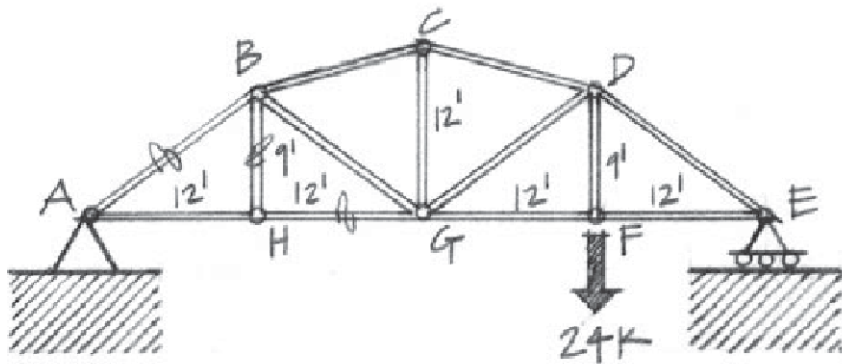

XC2. (I haven't checked this with anyone else yet.) For the truss as a whole $\sum F_x = 0$ gives $R_{Ax} = 0$. Then $\sum M_A = 0 = R_{Ey}(48') - 24k(36')$ gives $R_{Ey} = 18k$. Then $\sum F_y = 0 = R_{Ay} + R_{Ey} - 24k$ gives $R_{Ay} = 6k$. Now section the truss through members AB , BH , and GH and analyze the left-hand side. Then $\sum M_A = 0 = T_{BH}(12')$ gives $T_{BH} = 0$, which one can see by inspection of the vertical forces at joint H : bar BH is a "zero-force member." Then $\sum F_y = 0 = +6k + (3/5)T_{AB} + T_{BH}$ gives $T_{AB} = -10k$ (i.e. compression). Finally, $\sum F_x = 0 = (4/5)T_{AB} + T_{GH}$ gives $T_{GH} = 8k$.

Physics 8 — Wednesday, November 20, 2019

- ▶ HW11 is “due” on Friday, but you can turn it in on Monday, Nov 25, as it will probably take us an extra day to get through the material on beams.
- ▶ HW help: (Bill) Wed 4-6:30pm DRL 3C4, (Brooke/Grace) Thu 6-8pm DRL 2C4.
- ▶ This week, read/skim O/K Ch8 (more about beams).
- ▶ You may find my “equation sheet” to be a helpful summary of the key results from the Onouye/Kane reading:

<http://positron.hep.upenn.edu/p8/files/equations.pdf#page=12>