

- ▶ worksheet: positron.hep.upenn.edu/p8/files/ws22.pdf
- ▶ 4 problems + 2 XC. Q3 is a **long** truss problem!
- ▶ Problems 3 and 4 will reappear next time. So choose one of them to do today, and you can do the other one next Monday. Q3 is much longer (method of joints) but conceptually straightforward. Q4 is trickier (method of sections) but less tedious. Pick whichever one you're in the mood for today!
- ▶ Email **in advance** & file a CAR if you need to miss class.

torque (lever arm \times force): $\tau = r_{\text{perp}} F$

For equilibrium: $\sum F_x = 0$ $\sum F_y = 0$ $\sum_{\circlearrowleft P} \tau = 0$.

Usual torque convention: CCW minus CW. In choosing pivot P , note forces whose lines-of-action pass through P drop out of $\sum \tau$.

$$F^K = \mu_k F^N \quad F^S \leq \mu_s F^N$$

strain $e = (L - L_0)/L_0$ stress $f = Ee$ where $E = \text{Y.M.}$

stress = force/area

1. An elevator of mass (including passengers, at full capacity) 2000 kg hangs on a steel cable (of circular cross-section). Suppose that the building code requires a safety factor of 10 for such a cable. (The weakest point of the cable should not break when loaded with 10 times the maximum specified load.) (a) What should be the smallest diameter of the required cable? The weight of the cable itself can be neglected. (b) What should be the smallest diameter of the cable if the elevator accelerates upward at 2.45 m/s^2 (that's 0.25 g)? Use $8.0 \times 10^8 \text{ N/m}^2$ as the tensile strength of steel. Remember not to mix up radius, diameter, and cross-sectional area! The "safety factor of 10" in this problem means that the largest allowed stress in the cable is 1/10 of the quoted tensile strength.

2*. When a mass of 25 kg is suspended from the middle of a fixed straight aluminum wire (which is initially horizontal), the wire sags to make an angle of 2.0° with the horizontal, as shown below.

(a) What is the tension in each of two diagonal wire segments?
(b) If the original length of each wire segment was 1.000 m when it was horizontal (before the 25 kg mass was attached), what is its length when it is diagonal?
(c) What is the strain in the wire?
(d) If Young's modulus for aluminum is $7.0 \times 10^{10} \text{ N/m}^2$, what is the stress in the diagonal wire segments?
(e) If the wire has a circular cross-section, what is the wire radius? (You know the tension (force) and you know the tensile stress, so you can calculate the area, and hence the radius.)

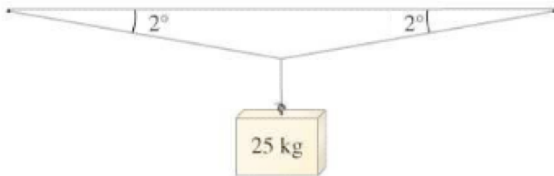

3*. (Long problem, counts double.) Using the method of joints, find the force in each bar of the truss shown below. Summarize the results on a diagram that indicates both the magnitude of each force and whether each bar is in tension or compression. [Hints: note that the reaction force at A must be parallel to bar AB , so the reaction force at A has only a vertical component. You can sum moments about F to find reaction force A_y . Then continue to use equilibrium for the truss as a whole to find reaction forces F_y and F_x . Then work at joint A to find T_{AB} . Then at joint F find T_{BF} then T_{EF} . Then at joint B find T_{BE} then T_{BC} . Then at joint C find T_{CE} then T_{CD} . Then at joint D find T_{DE} . As a check, I got $T_{CE} = 5 \text{ kN}$ and $T_{BC} = -3 \text{ kN}$.]

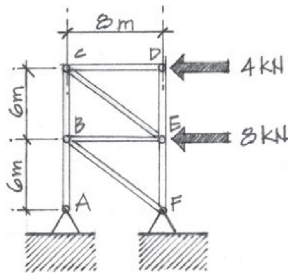

4*. Using the method of sections, solve for the forces in bars BC , CH , and FH in the truss shown above (right). Your solution must include an EFBDF for the half of the truss that you do not erase, with all external (or newly externalized) forces labeled. Indicate both the magnitudes of these forces and whether the bar is in tension or compression. [**Warning:** the angle of the 2 kN diagonal load is different from the angle of bar CE .]

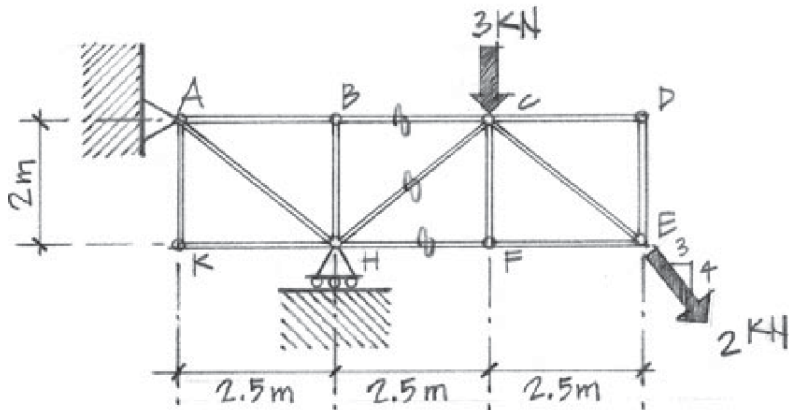

5XC*. Using the method of sections, solve for the forces in bars AB , BH , and HG in the truss shown below. You'll need to start by solving for at least a subset of the support ("reaction") forces. (Hint: a well-chosen torque equation lets you directly solve for the support force at E.) Then draw and label an EFB of the side of the truss that you do not erase. Indicate whether each of these bars is in tension or in compression. Use only one section cut through the truss. The truss is marked with distances in feet (!) and loads in "kips" (kilopounds). You can leave it as is, if you like, or you can pretend the markings are in meters and kilonewtons. Either way, use the given numbers; don't do any unit conversions.

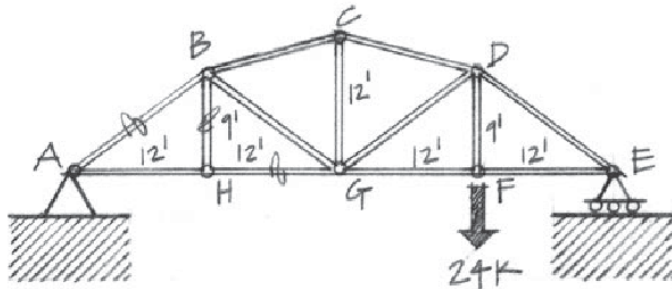

6XC*. A small ball is put into a cone and made to move at constant speed v in a horizontal circle of constant radius r . (See figure below. “Small” means that the ball’s rotational inertia is small enough to neglect.) (a) Draw a (Mazur-style) FBD for the ball. (b) What is the ball’s centripetal acceleration? (c) What is its tangential acceleration? (d) What force can counteract the force of gravity so that the ball keeps moving in a horizontal circle? (e) Use these insights to determine the height h the ball is circling above the bottom of the cone. [Hint: This is equivalent to finding the angle the cone makes with its vertical axis.]

