

- ▶ worksheet: positron.hep.upenn.edu/p8/files/ws23.pdf
- ▶ 4 problems + 3 XC. If time runs out, Q4 will become XC.
- ▶ You just skimmed O/K ch6 (centroids, second moment of area), which helps explain eg why an I-beam is I-shaped & why a joist is stiffer than a plank.
- ▶ Next: video lecture introducing beams. Then you'll **skim** O/K ch7 and ch8, which cover beams in more detail than we need.
- ▶ Our two remaining topics for the term are beams and vibration/oscillation.
- ▶ Email **in advance** & file a CAR if you need to miss class.



torque (lever arm \times force): $\tau = r_{\text{perp}} F$

For equilibrium: $\sum F_x = 0 \quad \sum F_y = 0 \quad \sum_{\circlearrowleft P} \tau = 0.$

Usual torque convention: CCW minus CW. In choosing pivot P , note forces whose lines-of-action pass through P drop out of $\sum \tau$.

$$F^K = \mu_k F^N$$

“equivalent” concentrated load $= \int w(x) dx$, applied at **centroid** of distributed load. “equivalent” means same support forces.

1*. (Repeated/continued from ws22/q3. Long problem, counts double.) Using the method of joints, find the force in each bar of the truss shown below. Summarize the results on a diagram that indicates both the magnitude of each force and whether each bar is in tension or compression. [Hints: note that the reaction force at A must be parallel to bar AB , so the reaction force at A has only a vertical component. You can sum moments about F to find reaction force A_y . Then continue to use equilibrium for the truss as a whole to find reaction forces F_y and F_x . Then work at joint A to find T_{AB} . Then at joint F find T_{BF} then T_{EF} . Then at joint B find T_{BE} then T_{BC} . Then at joint C find T_{CE} then T_{CD} . Then at joint D find T_{DE} . As a check, I got $T_{CE} = 5 \text{ kN}$ and $T_{BC} = -3 \text{ kN}$.]

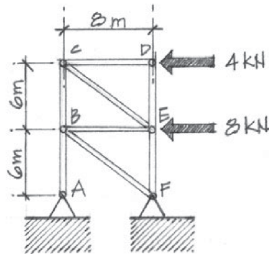

2*. (Repeated/postponed from ws22/q4.) Using the method of sections, solve for the forces in bars BC , CH , and FH in the truss shown above (right). Your solution must include an EFBD for the half of the truss that you do not erase, with all external (or newly externalized) forces labeled. Indicate both the magnitudes of these forces and whether the bar is in tension or compression. [Warning: the angle of the 2 kN diagonal load is different from the angle of bar CE .]

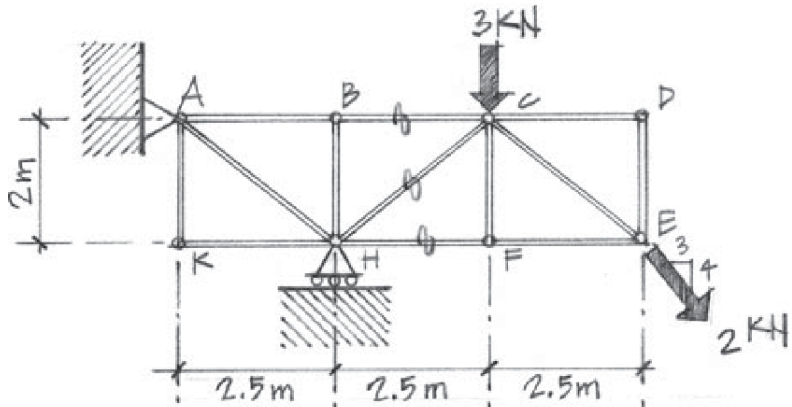

3*. A person wants to push a lamp (mass 8.0 kg) across the floor. The coefficient of friction between the lamp and the floor is $\mu_k = 0.20$. Calculate the maximum height x above the floor at which the person can push the lamp so that the lamp slides at constant speed rather than tips. The base of the lamp is a circle of radius 0.12 m. The lamp's center of gravity is directly above the center of the circular base. [When the lamp is just sitting at rest on the floor, the normal force exerted by the floor on the lamp is a "distributed force" whose centroid is at the center of the lamp's base. But when you push the lamp across the floor by its pole, the centroid of the distributed normal force moves forward. When you push the lamp by a point so high up the pole that the lamp is on the cusp of tipping over, the normal force is concentrated at the front edge of the base of the lamp. So you want to consider the extreme case where the normal force is concentrated at the front of the base. Using the front of the base as a pivot, you need to make sure that the lamp will not pivot clockwise about the front of the base, i.e. is in equilibrium.]

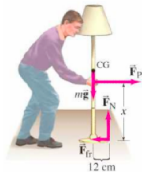

4*. [Save this problem for after you've done the first 3 problems. If time runs short, we'll mark it as **XC**.] Solve for the support "reaction" forces at A and B (i.e. the forces exerted by the supports at A and B on the beam) in the figure below. To do this, you will need to convert the distributed load into an equivalent concentrated load. Remember that a hinge/pin support exerts two force components on the beam (though one component may equal zero eg if the loads are all vertical), while a roller support exerts one force component (in the normal direction). The first step in your solution should be a redrawn EFB diagram showing "reaction" forces and the concentrated load that is equivalent (for the purpose of calculating reaction forces) to the distributed load. I apologize that you have not yet seen me solve an example like this in a video lecture, but once you get the idea, this problem is very similar to the diving-board problem you solved a week or two ago.

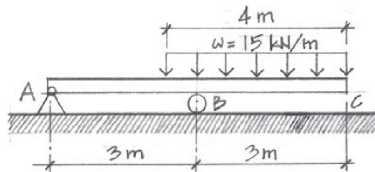

5XC*. Using the method of sections, solve for the forces in bars AB , BH , and HG in the truss shown below. You'll need to start by solving for at least a subset of the support ("reaction") forces. (Hint: a well-chosen torque equation lets you directly solve for the support force at E.) Then draw and label an EFB of the side of the truss that you do not erase. Indicate whether each of these bars is in tension or in compression. Use only one section cut through the truss. The truss is marked with distances in feet (!) and loads in "kips" (kilopounds). You can leave it as is, if you like, or you can pretend the markings are in meters and kilonewtons. Either way, use the given numbers; don't do any unit conversions.

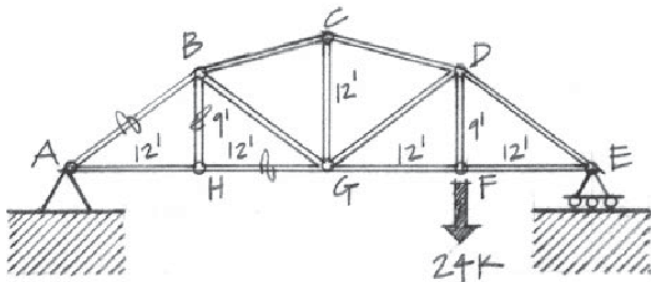

6XC*. A small ball is put into a cone and made to move at constant speed v in a horizontal circle of constant radius r . (See figure below. “Small” means that the ball’s rotational inertia is small enough to neglect.) (a) Draw a (Mazur-style) FBD for the ball. (b) What is the ball’s centripetal acceleration? (c) What is its tangential acceleration? (d) What force can counteract the force of gravity so that the ball keeps moving in a horizontal circle? (e) Use these insights to determine the height h the ball is circling above the bottom of the cone. [Hint: This is equivalent to finding the angle the cone makes with its vertical axis.]

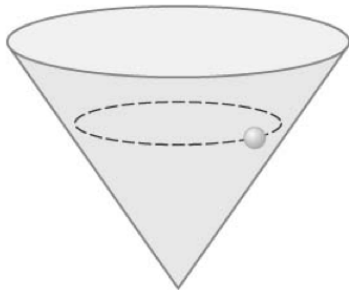

7XC*. (From O/K §5.4.) The steel rails of a continuous, straight railroad track are each 60 feet long and are laid with spaces between their ends of 0.25 inch at 70°F. (a) At what temperature will the rails touch end to end? (Use $\alpha = 6.5 \times 10^{-6}$ inch/inch/°F for steel's linear coefficient of thermal expansion, from Table 5.3.) (b) What compressive stress will be produced in the rails if the temperature rises to 150°F? (Use $E = 29 \times 10^6$ psi for the Young's modulus for steel.) [This problem may also leave you marveling that the US has not yet adopted the use of metric units.]

