

Physics 364, Fall 2014, reading due 2014-09-28.
Email your answers to ashmansk@hep.upenn.edu by 11pm on Sunday

Course materials and schedule are at <http://positron.hep.upenn.edu/p364>

Assignment: (a) First read through my notes (starting on next page), which directly relate to what we will do in the coming week's labs. (b) Then read Eggleston's §6.4 (pp 159–165). (c) Then skim Eggleston's §7.4.2 (pp 193–196) about Amplitude Modulation. (d) Then email me your answers to the questions below.

1. When we introduced the opamp golden rules last week, Rule #1 (that V_{out} does whatever is needed, such that $V_+ = V_-$) seemed a bit like magic. In your own words, why does opamp golden rule #1 really work?
2. Briefly define, in words, “input offset voltage,” and “input bias current.”
3. From the simple golden-rules picture, it makes no sense to include resistor R in the inverting amplifier shown in the figure below. But it turns out that if you are using an inexpensive opamp like the '741, and if R_1 and R_f are both quite large resistors, then the presence of resistor R can be helpful. How so?

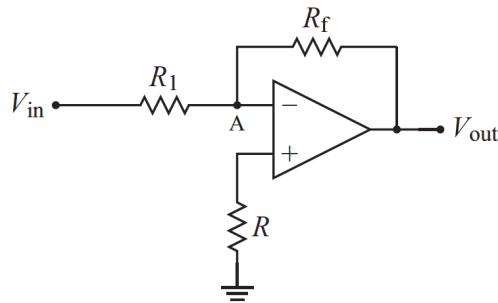

4. What are the largest output current a '741 opamp can supply, and the largest rate $\left| \frac{dV_{\text{out}}}{dt} \right|$ at which a '741 opamp's V_{out} can change? (The answers are just numbers, with units.)
5. Is there anything from this reading assignment that you found confusing and would like me to try to clarify? If you didn't find anything confusing, what topic did you find most interesting?
6. How much time did it take you to complete this assignment? Also, I continue to welcome suggestions for ways in which I might adapt the course to make the best possible use of your time.

Last week, we used the “Golden Rules” of idealized opamps to analyze many useful opamp circuits: followers, inverting and non-inverting amplifiers, integrators, summing amplifiers, etc. Our goals this week are (a) to see mathematically where the Golden Rules come from and (b) to explore the less-than-ideal behavior of real-life opamps. After break, we will begin to study transistors, which are the key components from which opamps are built; if all goes well, we will even build our own highly simplified opamp from transistors, so that you have some sense of what happens inside the opamp itself. For now, let’s see where the G.R. come from.

Rule #2 (that inputs draw negligible current) is easy to understand as a consequence of the opamp’s very high (typically $10^6 \sim 10^{12} \Omega$) input resistance. When we study transistor circuits, we will see how the large input resistance of transistor-based amplifiers arises.

Rule #1 (that negative feedback will adjust V_{out} such that $V_+ \approx V_-$) is less obvious. I said last week that Rule #1 was a consequence of the opamp’s very high (typically $\sim 10^6$ or more) gain, but I offered no details. The definition of the opamp’s voltage gain A is given by $V_{out} = A \cdot (V_+ - V_-)$. Here, A is the voltage gain of the opamp itself, and is typically a very large number (e.g. 10^6). (When you build amplifier circuits using opamps, those circuits have some smaller voltage gain, e.g. a gain of -10 for your inverting amplifier circuit for which $V_{out} = -10V_{in}$.) Let’s analyze a few opamp circuits for an opamp of large but finite gain A , and then see what happens as $A \rightarrow \infty$.

For the opamp **follower** (shown below, left), we find

$$V_{out} = A \cdot (V_+ - V_-) = A \cdot (V_{in} - V_{out}) \Rightarrow V_{out} \cdot (1 + A) = AV_{in} \Rightarrow V_{out} = \frac{A}{1 + A} V_{in}.$$

So in the limit $A \rightarrow \infty$, we have $V_{out} \rightarrow V_{in}$, which is the same result that we found by using the Golden Rules.

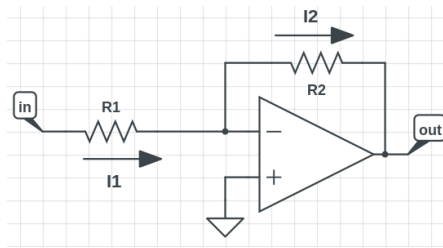
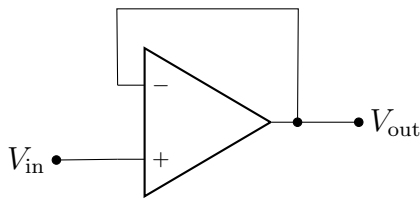

For the **inverting amplifier** (shown above, right), we find

$$V_{out} = A \cdot (V_+ - V_-) = -AV_- \Rightarrow V_- = -\frac{V_{out}}{A}.$$

Using the fact that R_{in} of the opamp is very large (large enough to prevent any non-negligible fraction of I_1 from flowing into the opamp), we find $I_2 = I_1$. Thus,

$$\frac{V_{in} - V_-}{R_1} = \frac{V_- - V_{out}}{R_2} \Rightarrow \frac{1}{R_1} \left(V_{in} + \frac{V_{out}}{A} \right) = -\frac{1}{R_2} \left(\frac{V_{out}}{A} + V_{out} \right).$$

After rearranging the above expression, we find

$$\frac{V_{\text{out}}}{V_{\text{in}}} = - \frac{R_2/R_1}{1 + \frac{1}{A} \left(1 + \frac{R_2}{R_1}\right)} \rightarrow - \frac{R_2}{R_1}$$

in the limit $A \rightarrow \infty$, which again matches the Golden Rules result. By the way, what is V_- now?

$$V_- = - \frac{V_{\text{out}}}{A} = - \frac{R_2}{R_1} \cdot \frac{V_{\text{in}}}{A + 1 + \frac{R_2}{R_1}} \rightarrow 0$$

in the limit $A \rightarrow \infty$. So V_- is a “virtual ground,” as the Golden Rules predict.

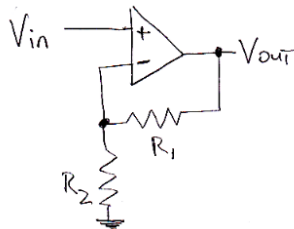

Let's look at the **non-inverting amplifier** (shown above). Again, we write $V_{\text{out}} = A \cdot (V_+ - V_-)$, which is just the definition of the amplifier's gain A . Then the schematic diagram gives us $V_+ = V_{\text{in}}$ and (using the fact that the inputs draw negligible current) $V_- = \frac{R_2}{R_1 + R_2} V_{\text{out}}$. So then

$$V_{\text{out}} = A \cdot \left(V_{\text{in}} - \frac{R_2 V_{\text{out}}}{R_1 + R_2} \right) = \frac{V_{\text{in}} A}{1 + \frac{AR_2}{R_1 + R_2}} = \frac{V_{\text{in}} A \cdot (R_1 + R_2)}{R_1 + R_2 + AR_2} \rightarrow \frac{R_1 + R_2}{R_2} V_{\text{in}}$$

in the limit $A \rightarrow \infty$. So $V_{\text{out}} = \left(1 + \frac{R_1}{R_2}\right) V_{\text{in}}$, as we found more easily by using the Golden Rules. Let's also check the Golden Rules' prediction that $V_- = V_+$.

$$V_- = \frac{R_2 V_{\text{out}}}{R_1 + R_2} = \frac{R_2}{R_1 + R_2} \cdot \frac{V_{\text{in}} A \cdot (R_1 + R_2)}{R_1 + R_2 + AR_2} = \frac{R_2 V_{\text{in}} A}{R_1 + R_2 + AR_2} \rightarrow V_{\text{in}}$$

in the $A \rightarrow \infty$ limit. Since $V_{\text{in}} = V_+$, we again confirm the rules' prediction that $V_- = V_+$, as long as negative feedback is present with very high gain.

If V_+ were at just slightly higher potential than V_- , then V_{out} would move higher; this in turn would move V_- higher, because a fraction of V_{out} is fed back into V_- . Conversely, if V_+ were slightly lower than V_- , then V_{out} would move lower; this in turn would move V_- lower. The negative feedback causes V_{out} to move such that V_- moves toward V_+ . In the $A \rightarrow \infty$ limit, $V_+ = V_-$.

So you can see that the Golden Rules are just a shortcut for evaluating the consequences of $A \rightarrow \infty$ and $R_{\text{in}} \rightarrow \infty$, for cases where negative feedback is present.

Thus far, we have studied idealized opamps that have infinite gain, whose inputs draw absolutely no current, and that generally lack the imperfections of real-world

opamps. Let's look at the LM741 opamp's official data sheet (shown on the next several pages). It quotes these parameters:

Parameter	typical	worst-case
Input Offset Voltage	1 mV	5 mV
Input Bias Current	80 nA	500 nA
Input Offset Current	20 nA	200 nA
Input Resistance	2 M Ω	300 k Ω
Voltage Gain	2×10^5	5×10^4
Output Voltage Swing ($V_{\text{supply}} = \pm 15 \text{ V}$)	$\pm 14 \text{ V}$	$\pm 10 \text{ V}$
Output Short-Circuit Current	25 mA	
Bandwidth	1.5 MHz	
Slew Rate	0.5 V/ μs	

It is important to know what these numbers mean when you select an opamp for your own project, and it is helpful to be aware of these limitations (and how to work around them) when you build or study a circuit using a given opamp.

The '741 is an inexpensive (\$0.75) and simple opamp — like a 1972 Dodge Dart. You can get far better performance from newer components. By exploring the limitations of the '741 (which are probably worse than those for opamps you would use in real life), you can understand the ideas that you must consider when using or selecting an opamp for projects that you may take on in the future.

The **input offset voltage**, V_{os} , is the small ΔV that must appear between the opamp's + and - inputs, in order to make $V_{\text{out}} = 0$. So then $V_{\text{out}} = A \cdot (V_+ - V_-)$ is replaced by $V_{\text{out}} = A \cdot (V_+ - V_- - V_{\text{os}})$. For the '741, V_{os} is a few millivolts. This effect is due to small imperfections in the input stage of the opamp.

The **input bias current**, I_{bias} , is the small, finite DC current drawn by the + and - inputs. In practice, the + and - inputs will have slightly different bias currents, which we can call I_{b+} and I_{b-} . Then $I_{\text{bias}} \equiv \frac{1}{2}(I_{b+} + I_{b-})$, while the **input offset current** is $I_{\text{offset}} \equiv |I_{b+} - I_{b-}|$. Typically I_{offset} is smaller than I_{bias} by a factor between 2 and 10. For the '741, the bias and offset currents are $\mathcal{O}(100 \text{ nA})$. You'll see when we study transistors after fall break that transistor-based amplifiers (particularly those made with Bipolar Junction Transistors rather than with Field Effect Transistors) draw a small but nonzero current at their inputs; this is the origin of the bias current.

(Continued after '741 data sheet pages.)

LM741 Operational Amplifier

General Description

The LM741 series are general purpose operational amplifiers which feature improved performance over industry standards like the LM709. They are direct, plug-in replacements for the 709C, LM201, MC1439 and 748 in most applications. The amplifiers offer many features which make their application nearly foolproof: overload protection on the input and

output, no latch-up when the common mode range is exceeded, as well as freedom from oscillations.

The LM741C is identical to the LM741/LM741A except that the LM741C has their performance guaranteed over a 0°C to +70°C temperature range, instead of -55°C to +125°C.

Features

Connection Diagrams

Metal Can Package

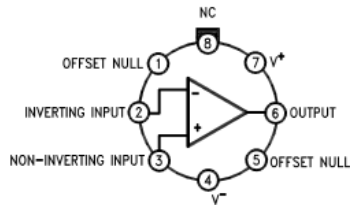

00934102

Note 1: LM741H is available per JM38510/10101

**Order Number LM741H, LM741H/883 (Note 1),
LM741AH/883 or LM741CH**
See NS Package Number H08C

Dual-In-Line or S.O. Package

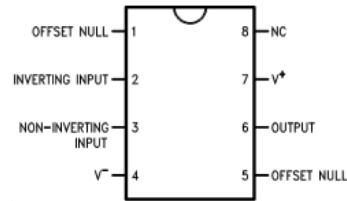

00934103

Order Number LM741J, LM741J/883, LM741CN
See NS Package Number J08A, M08A or N08E

Ceramic Flatpak

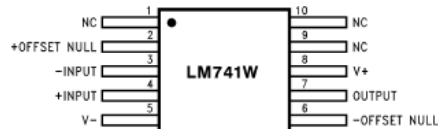

00934106

Order Number LM741W/883
See NS Package Number W10A

Typical Application

Offset Nulling Circuit

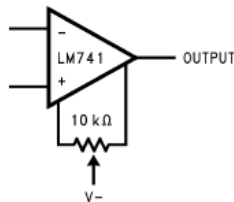

00934107

Absolute Maximum Ratings (Note 2)

If Military/Aerospace specified devices are required, please contact the National Semiconductor Sales Office/ Distributors for availability and specifications.

(Note 7)

	LM741A	LM741	LM741C
Supply Voltage	±22V	±22V	±18V
Power Dissipation (Note 3)	500 mW	500 mW	500 mW
Differential Input Voltage	±30V	±30V	±30V
Input Voltage (Note 4)	±15V	±15V	±15V
Output Short Circuit Duration	Continuous	Continuous	Continuous
Operating Temperature Range	-55°C to +125°C	-55°C to +125°C	0°C to +70°C
Storage Temperature Range	-65°C to +150°C	-65°C to +150°C	-65°C to +150°C
Junction Temperature	150°C	150°C	100°C
Soldering Information			
N-Package (10 seconds)	260°C	260°C	260°C
J- or H-Package (10 seconds)	300°C	300°C	300°C
M-Package			
Vapor Phase (60 seconds)	215°C	215°C	215°C
Infrared (15 seconds)	215°C	215°C	215°C
See AN-450 "Surface Mounting Methods and Their Effect on Product Reliability" for other methods of soldering surface mount devices.			
ESD Tolerance (Note 8)	400V	400V	400V

Electrical Characteristics (Note 5)

Parameter	Conditions	LM741A			LM741			LM741C			Units
		Min	Typ	Max	Min	Typ	Max	Min	Typ	Max	
Input Offset Voltage	$T_A = 25^\circ\text{C}$ $R_S \leq 10\text{ k}\Omega$ $R_S \leq 50\Omega$		0.8	3.0		1.0	5.0		2.0	6.0	mV mV
	$T_{AMIN} \leq T_A \leq T_{AMAX}$ $R_S \leq 50\Omega$ $R_S \leq 10\text{ k}\Omega$			4.0			6.0			7.5	mV mV
Average Input Offset Voltage Drift				15							$\mu\text{V}/^\circ\text{C}$
Input Offset Voltage Adjustment Range	$T_A = 25^\circ\text{C}$, $V_S = \pm 20\text{V}$	±10				±15			±15		mV
Input Offset Current	$T_A = 25^\circ\text{C}$		3.0	30		20	200		20	200	nA
	$T_{AMIN} \leq T_A \leq T_{AMAX}$			70		85	500			300	nA
Average Input Offset Current Drift				0.5							$\text{nA}/^\circ\text{C}$
Input Bias Current	$T_A = 25^\circ\text{C}$		30	80		80	500		80	500	nA
	$T_{AMIN} \leq T_A \leq T_{AMAX}$			0.210			1.5			0.8	μA
Input Resistance	$T_A = 25^\circ\text{C}$, $V_S = \pm 20\text{V}$	1.0	6.0		0.3	2.0		0.3	2.0		$\text{M}\Omega$
	$T_{AMIN} \leq T_A \leq T_{AMAX}$, $V_S = \pm 20\text{V}$	0.5									$\text{M}\Omega$
Input Voltage Range	$T_A = 25^\circ\text{C}$							±12	±13		V
	$T_{AMIN} \leq T_A \leq T_{AMAX}$				±12	±13					V

Electrical Characteristics (Note 5) (Continued)											
Parameter	Conditions	LM741A			LM741			LM741C			Units
		Min	Typ	Max	Min	Typ	Max	Min	Typ	Max	
Large Signal Voltage Gain	$T_A = 25^\circ\text{C}$, $R_L \geq 2\text{ k}\Omega$ $V_S = \pm 20\text{V}$, $V_O = \pm 15\text{V}$ $V_S = \pm 15\text{V}$, $V_O = \pm 10\text{V}$	50			50	200		20	200		V/mV V/mV
	$T_{AMIN} \leq T_A \leq T_{AMAX}$, $R_L \geq 2\text{ k}\Omega$, $V_S = \pm 20\text{V}$, $V_O = \pm 15\text{V}$ $V_S = \pm 15\text{V}$, $V_O = \pm 10\text{V}$	32			25			15			V/mV V/mV
	$V_S = \pm 5\text{V}$, $V_O = \pm 2\text{V}$	10									V/mV
Output Voltage Swing	$V_S = \pm 20\text{V}$ $R_L \geq 10\text{ k}\Omega$ $R_L \geq 2\text{ k}\Omega$	± 16									V V
	$V_S = \pm 15\text{V}$ $R_L \geq 10\text{ k}\Omega$				± 12	± 14		± 12	± 14		V
	$R_L \geq 2\text{ k}\Omega$				± 10	± 13		± 10	± 13		V
Output Short Circuit Current	$T_A = 25^\circ\text{C}$	10	25	35		25			25		mA
	$T_{AMIN} \leq T_A \leq T_{AMAX}$	10		40							mA
Common-Mode Rejection Ratio	$T_{AMIN} \leq T_A \leq T_{AMAX}$ $R_S \leq 10\text{ k}\Omega$, $V_{CM} = \pm 12\text{V}$				70	90		70	90		dB
	$R_S \leq 50\Omega$, $V_{CM} = \pm 12\text{V}$	80	95								dB
Supply Voltage Rejection Ratio	$T_{AMIN} \leq T_A \leq T_{AMAX}$, $V_S = \pm 20\text{V}$ to $V_S = \pm 5\text{V}$										dB
	$R_S \leq 50\Omega$ $R_S \leq 10\text{ k}\Omega$	86	96		77	96		77	96		dB
Transient Response	$T_A = 25^\circ\text{C}$, Unity Gain	Rise Time		0.25	0.8		0.3		0.3		μs
		Overshoot		6.0	20		5		5		%
Bandwidth (Note 6)	$T_A = 25^\circ\text{C}$	0.437	1.5								MHz
Slew Rate	$T_A = 25^\circ\text{C}$, Unity Gain	0.3	0.7			0.5		0.5			V/ μs
Supply Current	$T_A = 25^\circ\text{C}$					1.7	2.8	1.7	2.8		mA
Power Consumption	$T_A = 25^\circ\text{C}$ $V_S = \pm 20\text{V}$ $V_S = \pm 15\text{V}$		80	150							mW mW
	LM741A $V_S = \pm 20\text{V}$					50	85	50	85		mW
	$T_A = T_{AMIN}$ $T_A = T_{AMAX}$			165							mW mW
	LM741 $V_S = \pm 15\text{V}$										mW
	$T_A = T_{AMIN}$ $T_A = T_{AMAX}$					60	100				mW mW
						45	75				mW

Note 2: "Absolute Maximum Ratings" indicate limits beyond which damage to the device may occur. Operating Ratings indicate conditions for which the device is functional, but do not guarantee specific performance limits.

Electrical Characteristics (Note 5) (Continued)

Note 3: For operation at elevated temperatures, these devices must be derated based on thermal resistance, and T_j max. (listed under "Absolute Maximum Ratings"). $T_j = T_A + (\theta_{JA} P_D)$.

Thermal Resistance	Cerdip (J)	DIP (N)	HO8 (H)	SO-8 (M)
θ_{JA} (Junction to Ambient)	100°C/W	100°C/W	170°C/W	195°C/W
θ_{JC} (Junction to Case)	N/A	N/A	25°C/W	N/A

Note 4: For supply voltages less than $\pm 15V$, the absolute maximum input voltage is equal to the supply voltage.

Note 5: Unless otherwise specified, these specifications apply for $V_S = \pm 15V$, $-55^\circ C \leq T_A \leq +125^\circ C$ (LM741/LM741A). For the LM741C/LM741E, these specifications are limited to $0^\circ C \leq T_A \leq +70^\circ C$.

Note 6: Calculated value from: BW (MHz) = 0.35/Rise Time(μs).

Note 7: For military specifications see RETS741X for LM741 and RETS741AX for LM741A.

Note 8: Human body model, 1.5 k Ω in series with 100 pF.

Schematic Diagram

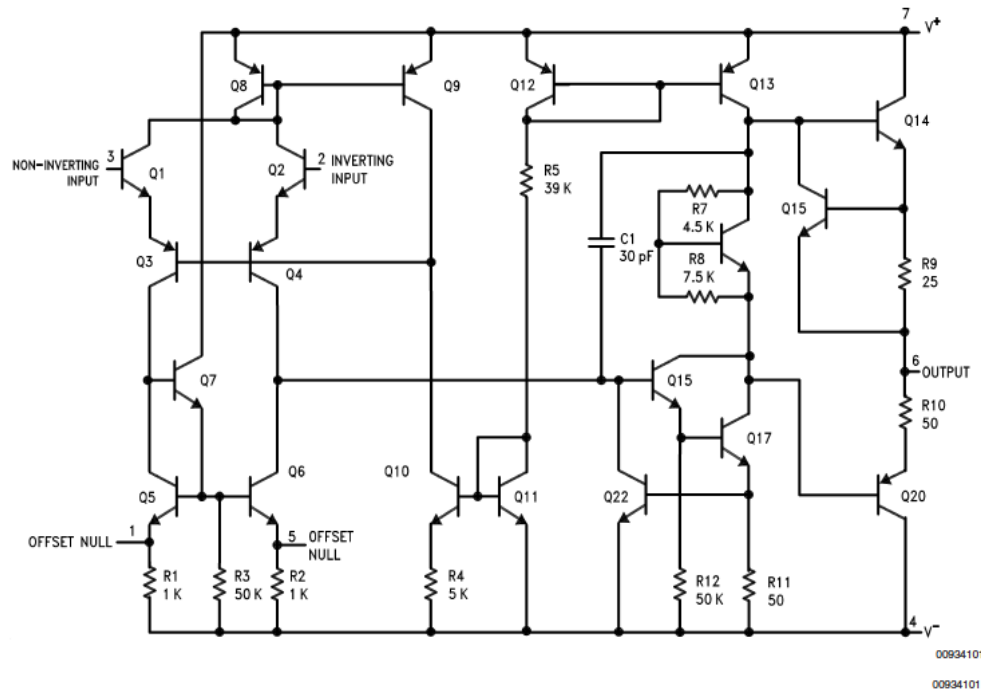

A real opamp's input resistance R_{in} and its gain A are large but of course finite. For the '741, $R_{in} \sim \mathcal{O}(10^6 \Omega)$, while $A \sim \mathcal{O}(10^5)$. The internal circuitry of the '741 uses Bipolar Junction Transistors; opamps that instead use Field Effect Transistors have enormously larger input resistance (e.g. $\mathcal{O}(10^{12} \Omega)$). These two facts will start to make more sense once we study transistors in the coming weeks.

As noted last week, V_{out} cannot swing beyond the power supply “rails.” In fact, the '741 typically will only go to ± 14 V or less, if powered with ± 15 V. Some opamps offer “rail-to-rail” output, which is handy when using relatively small $V_{S\pm}$.

The **largest current** that a '741 opamp's V_{out} pin will “source” or “sink” (which verb you choose depends on whether positive current is flowing out of or into the opamp) is about 25 mA. This can be an issue when driving a big 8Ω speaker, charging a big capacitor, driving a long cable, driving a motor, etc. Sometimes one enlists the help of a high-current external transistor in these cases. (This too will make more sense once we have studied transistors.)

Every opamp has some finite **bandwidth**, i.e. the range of frequencies over which it can amplify. Usually the frequency response of an opamp looks like that of an RC low-pass filter (figures below from earlier notes). Usually the log-log graph (left) is shown, but keep in mind that the shape looks quite different on a linear scale (right).

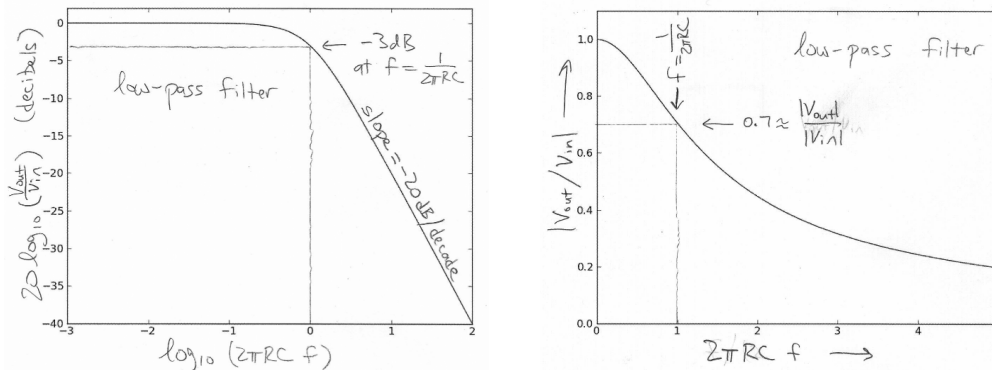



Remember that for an RC low-pass filter,

$$\left| \frac{V_{out}}{V_{in}} \right| = \left| \frac{\left(\frac{1}{j\omega C}\right)}{R + \left(\frac{1}{j\omega C}\right)} \right| = \frac{1}{\sqrt{1 + (2\pi fRC)^2}} \rightarrow \frac{1}{2\pi RCf} \quad (\text{for } f \gg \frac{1}{2\pi RC})$$

At very high frequency, the product $f \cdot \left| \frac{V_{out}}{V_{in}} \right|$ for an RC low-pass filter is constant. Because an opamp's gain follows this same curve at high frequency, one often speaks of the opamp's **gain \times bandwidth product**. Let's look at an example using typical values for a '741 opamp: bandwidth = 1.5 MHz, and gain = 2×10^5 (or about 106 dB).¹ You can see that **bandwidth** for an opamp does not mean f_{3dB} . It means the frequency at which gain = 1.

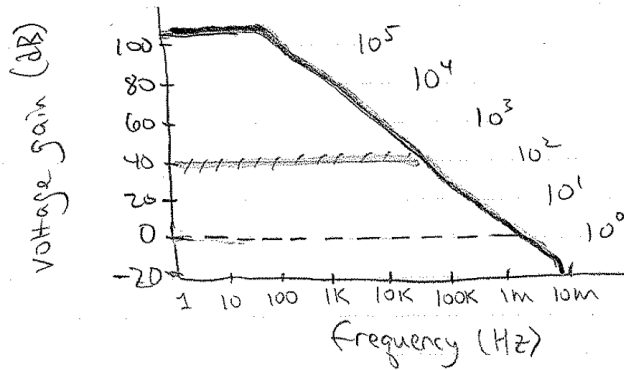
¹The figure below is my hand-drawn reproduction of Horowitz & Hill figure 4.80, page 243.



If I build an opamp follower  using the '741, its gain vs. frequency will look like the dashed curve above. The follower will have a *voltage gain* $|V_{out}|/|V_{in}| = 1$ (expressed logarithmically, this is 0 dB) from DC up to 1.5 MHz, after which $|V_{out}|/|V_{in}|$ will fall in proportion to $1/f$.



If I build a $\times 100$ amplifier using the '741, its gain $|V_{out}|/|V_{in}|$ vs. frequency will look like the hatched curve above. The $\times 100$ amplifier circuit will have voltage gain $|V_{out}|/|V_{in}| = 100$ (expressed logarithmically, this is +40 dB) from DC up to 15 kHz, after which $|V_{out}|/|V_{in}|$ will fall as $1/f$. Graphically, the gain of your amplifier circuit takes on the golden-rules value from low frequency up to the point at which it meets the opamp's own gain-vs-frequency curve, then follows the opamp's curve beyond that. The reason is that the gain of your amplifier circuit cannot exceed the gain of the opamp itself.

You can see how the dashed and hatched curves arise mathematically by taking the V_{out} expressions we derived (for opamp follower, for non-inverting amplifier, etc.) for finite opamp gain A , and letting $A(f)$ (the opamp's gain as a function of frequency) be the solid curve from the figure above.

Why the opamp's gain vs. frequency (a.k.a. its *frequency response*) rolls off in this way at high frequency relates to a subtle topic called **frequency compensation**. Let me try to explain it briefly. You'll also see this effect illustrated in an optional part of an upcoming lab. Remember that once we started adding capacitors to our circuits, we had to worry about phase shifts between V_{in} and V_{out} , and that these phase shifts varied with frequency. It turns out that the transistors from which opamps are made will inevitably include some finite capacitance. (Any set of electrodes placed a finite distance apart will have some finite capacitance.) So the internal workings of the opamp create unavoidable phase shifts, which tend to grow with frequency. If at some frequency the phase shift between the opamp's inputs and its output reaches 180° , then (above that frequency) your circuit's negative feedback will instead

become positive feedback: it is as if you had flipped the sign of V_{out} at high frequency. (Remember that $e^{j\pi} = -1$.) As we will see next week when we discuss comparators, positive feedback makes a circuit unstable, such that even a tiny change in V_{in} can make V_{out} swing wildly back and forth. This is definitely not what you want: you do not want your opamp circuit, when given no input, to chatter uncontrollably at some high frequency. The opamp designer's cure for this problem is to reduce the opamp's gain deliberately at high frequencies (by building a low-pass filter into the opamp's internal circuitry), so that $|\mathbf{A}(f)| \ll 1$ well before the phase of $\mathbf{A}(f)$ reaches 180° . That cure is called *frequency compensation*.

Finally, the '741 opamp's maximum **slew rate** is quoted as $0.5 \text{ V}/\mu\text{s}$. The slew rate refers to the opamp's largest possible $\left| \frac{dV_{\text{out}}}{dt} \right|$. It is a kind of saturation of the opamp's output, but in this case it is $\frac{d}{dt}V_{\text{out}}$ that saturates rather than V_{out} itself. This may arise, for example, if an internal stage of the opamp has a current limit and is charging an internal capacitance. Since the opamp's **slew rate** represents a form of saturation, it is a **non-linear** effect — it is a frequency limit that depends upon amplitude. Thus, driving an opamp close to its slew rate can distort your signal — e.g. introducing Fourier components² into V_{out} that are not present in V_{in} .

Slewing is also pertinent when you need to get from $V_{\text{out}}(\text{min})$ to $V_{\text{out}}(\text{max})$ as quickly as possible — something we will discuss when we introduce the *comparator* next week.

A topic that appeared in Lab 7 but so far not in the reading is the effect of feedback on an opamp circuit's **output resistance** (a.k.a. Thévenin resistance, a.k.a. source resistance). Let's analyze for finite gain the example from Lab 7 (part 1.5), in which we artificially gave the '741 opamp an output resistance of $1 \text{ k}\Omega$, as shown below.

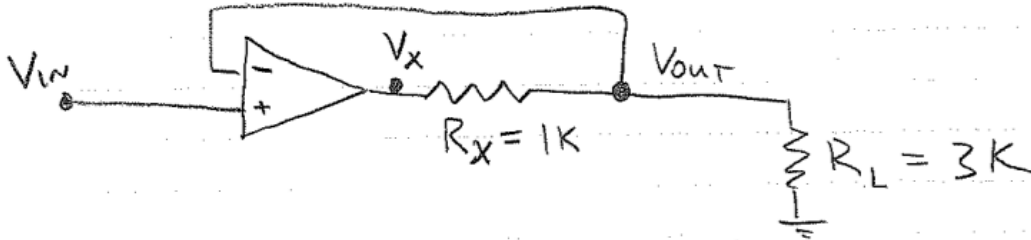

For finite opamp gain A ,

$$V_X = A \cdot (V_+ - V_-) = A \cdot (V_{\text{in}} - V_{\text{out}}).$$

²For a linear system, $O(a \cdot V_1(t) + b \cdot V_2(t)) = a \cdot O(V_1(t)) + b \cdot O(V_2(t))$. For the sum of two inputs, the output is just the sum of the corresponding outputs. If the input to a linear system contains only frequencies f_1 and f_2 , the output will also contain only those two frequencies f_1 and f_2 . But a non-linear system can respond at frequencies not present in the original input, such as $2f_1$, $2f_2$, $f_1 + f_2$, $f_1 - f_2$, etc. (As an example of a non-linear operation, try squaring the input: $(\cos(\omega_1 t) + \cos(\omega_2 t))^2$ expands to $\cos((\omega_1 - \omega_2)t) + \cos((\omega_1 + \omega_2)t) + \frac{1}{2} \cos(2\omega_1 t) + \frac{1}{2} \cos(2\omega_2 t) + 1$.) This is why your stereo sounds awful if you turn up the volume so far that some part of the system (maybe the amplifier, maybe the speakers) begins to saturate: the response is no longer linear, so the frequency content is no longer correct.

But $V_{\text{out}} = \frac{R_L}{R_X + R_L} V_X$, so then

$$V_{\text{out}} \cdot \frac{R_X + R_L}{R_L} = V_X = A \cdot (V_{\text{in}} - V_{\text{out}}).$$

After rearranging, we have

$$V_{\text{out}} = V_{\text{in}} \cdot \frac{A}{A + 1 + \frac{R_X}{R_L}} = \frac{V_{\text{in}}}{1 + \frac{1}{A} + \frac{R_X}{AR_L}}.$$

The output resistance R_{out} of the follower circuit (i.e. of everything to the left of R_L) measures how much V_{out} will droop as we increase I_{out} . In other words, $R_{\text{out}} = -\frac{dV_{\text{out}}}{dI_{\text{out}}}$. Let's define $g \equiv \frac{1}{R_L}$, so then $I_{\text{out}} = V_{\text{out}}/R_L = gV_{\text{out}}$. Then

$$\frac{-1}{R_{\text{out}}} = \frac{dI_{\text{out}}}{dV_{\text{out}}} = \frac{d(gV_{\text{out}})}{dV_{\text{out}}} = g + V_{\text{out}} \frac{dg}{dV_{\text{out}}} = g + \frac{V_{\text{out}}}{dV_{\text{out}}/dg},$$

and plugging in dV_{out}/dg computed below,

$$\frac{-1}{R_{\text{out}}} = g - V_{\text{out}} \cdot \frac{A + 1 + gR_X}{V_{\text{out}}R_X} = g - \frac{A + 1}{R_X} - g = -\frac{A + 1}{R_X} \Rightarrow \boxed{R_{\text{out}} = \frac{R_X}{1 + A}}.$$

To get dV_{out}/dg above, I used

$$V_{\text{out}} = \frac{V_{\text{in}}}{1 + \frac{1}{A} + \frac{gR_X}{A}} \Rightarrow \frac{dV_{\text{out}}}{dg} = -\frac{V_{\text{in}} \cdot R_X/A}{\left(1 + \frac{1}{A} + \frac{gR_X}{A}\right)^2} = -\frac{V_{\text{out}}R_X}{A + 1 + gR_X}.$$

Probably if I were more clever, I could have shown this in fewer steps. But one thing I like about the above computation is that it uses the intuitive meaning of R_{out} — that it quantifies how much V_{out} decreases (“droops”) as more current is drawn from the circuit — and it shows that reducing R_{load} is the mechanism for increasing I_{out} , which in turn reduces V_{out} for a non-ideal voltage source. Also, I hope this argument shows you that it is in fact the opamp’s high gain, used with negative feedback, that causes most opamp circuits to be nearly-ideal voltage sources. (In the high-gain limit $A \rightarrow \infty$, we find $R_{\text{out}} \rightarrow 0$ in the boxed expression above for the opamp follower.) Even if the opamp itself had a non-negligible output resistance (which we model as R_X), the opamp follower as a whole would still have a very small output resistance, because of the factor $1 + A$ in the denominator.

One last topic: **Amplitude Modulation**. We’re finally ready to build an AM radio receiver, now that you know how to amplify small signals. I’ve put the last few pages of Tom Hayes’s notes on diodes at the back of the printed version of this handout, as he has a nice step-by-step illustration of demodulating an AM signal. If you have time, you might also skim through (maybe just look at the graphs) this Wikipedia page: en.wikipedia.org/wiki/Amplitude_modulation.